



MarineKart®

Marine Accessories & Steering System

www.marinekartindia.com

About Us

Established in the year 2011, MarineKart is one of the largest full marine accessories dealers in India. With a strong presence in the national and international arena, we have all kinds of accessories like mechanical & hydraulic steering systems, various kinds of pumps, impellers, fuel tank sensors, battery switches, gauges, anodes, fenders and anchors. We also have other accessories like binoculars, lanterns, LED lights, bearings, etc.

We take extreme pride in the high quality and durable products that we provide to our clients and customers.

Our clients range from small individual fishermen to large multi-national shipping companies. We also supply marine engine spare parts for both inboard and outboard vessels. We also take custom sourcing orders and procure products based on your requirement.

Contact us with your requirements.



+91-992-302-6865
+91-9518-999-484



info@marinekartindia.com
sales@marinekartindia.com

www.marinekartindia.com

Serial No:	Description	Page Number
01	MECHANICAL STEERING SYSTEM	01
02	HYDRAULIC STEERING SYSTEM	03
03	TRIM TAB	18
04	BILGE PUMP & WATER PUMP	19
05	BRONZE VALVE & SEA WATER SCOOP	23
06	FUEL TANK & FUEL CONNECTOR PRIMING PUMP	28
07	IMPELLER & FUEL TANK SENSOR	32
08	BATTERY SWITCH & GAUGES	35
09	SWITCH PANELS	39
10	KEYS & BULBS	40
11	NAVIGATION LIGHTS & LED LIGHTS	41
12	BATTERY CHARGER	42
13	WIPER, MOTOR & ARM	43
14	FENDERS & ANCHORS	44
15	TOWABLES	45
16	ELECTRIC TOILET & MANUAL TOILET	46
17	DECK FITTINGS	50
18	HULL, DECK HARDWARE, HINGES & CLEATS	51
19	CABIN HARDWARE	52
20	CUTLESS BEARINGS	53
21	PORTHOLES	57

Mechanical steering system mod. G.10



Cod. G.10 helm group

- Interc hangeable with T.67 Ultra ex® and SH8050 Tele ex ®
- Packaged with 90° bezel kit
- Made of corrosion resistant material
- Made by a planetary gear design, with a central gear and three satellite gears that rotate on their axis
- Lock to lock steering wheel turns: 3,8.
- Max wheel diameter 400 mm.
- Exceeds EN 29775 safety standards
- Applications for use with outboard engines up to 40 KW (55 Hp).
- Steering systems G.10 with cable C.614.05 are not to be used on boats equipped with engines that exceed the maximum horsepower rating of the

cod. G.11

- Helm group with 20° bezel

cod C.614.05 steering cable

- Interchangeable with M.58 Ultra ex® and SSC 1300 Tele ex®
- Stroke 230 mm.
- All stainless steel output end of cable
- Minimum steering cable bend radius Interc 200 mm.

In order to replace a not threaded terminal cable, it's important to refer the number written on the external black part of the cable.

How to measure for replacement steering cables

Order length: "D" dimension + 22" and round up to the next whole foot.

Example: $D = 133" + 22" = 155"$ (12'9").

Round up to 13 ft.

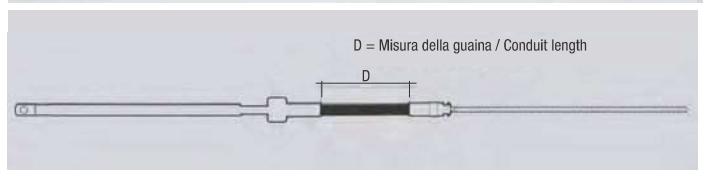
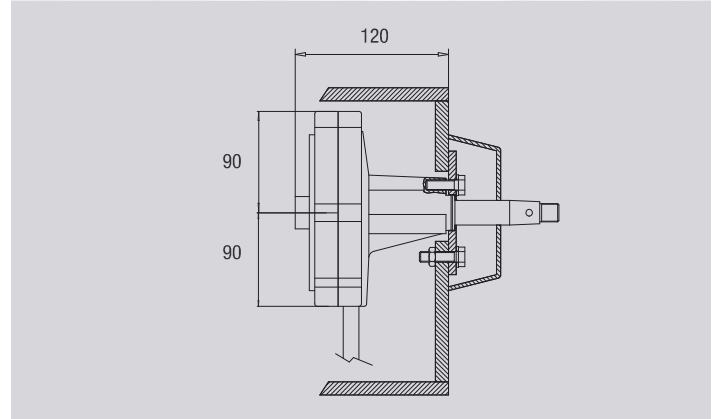

Mechanical steering system mod. G.12



Part No. G.12 helm group

- Interc hangeable with T.71 Ultra ex® and SAFE-T Teleflex®
- Packaged with 9 0° bezel kit
- Made of corrosion resistant material
- Made by a planetary gear design, with a central gear and three satellite gears that rotate on their axis
- Lock to lock steering wheel turns: 3,8.
- Max wheel diameter 400 mm.
- Exceeds EN 28848 safety standards
- Steering systems G.12 with cable C.17.05 are not to be used on boats equipped with engines that exceed the maximum horsepower rating of the boat.

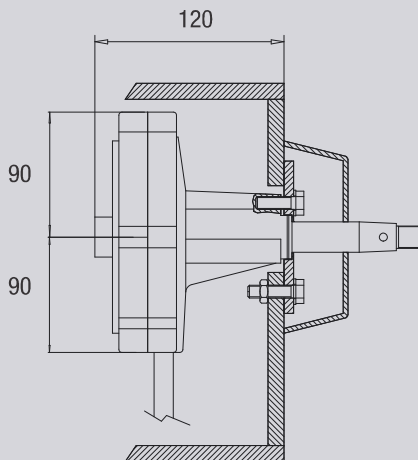

Part no. G.13

- Helm group with 20° bezel kit.

KIT TIMONERIE IDRAULICHE Hydraulic Steering Kits



Our most popular outboard steering

Kits:

- **GF90BT** fino a 80 HP
- **GF150BRT** fino a 150 HP
- **GF300BT** fino a 300 HP
- **GF350HD** fino a 350 HP

Other steering kit:

- **GF150T** fino a 150 HP
- **GF150RT** fino a 150 HP
- **GF300AT** fino a 300 HP
- **GF300CT** fino a 300 HP
- **GF300RT** fino a 300 HP

Steering kit for special applications:

- **GF300BVT**
- **GE50S**

Stern drive steering kits

Inboard steering kits



NEW!

GF90BT

HYDRAULIC STEERING SYSTEMS UP TO 80HP

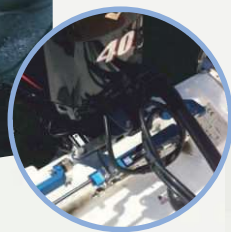

Hydraulic steering system kit up to 80 Hp

GF.90BT

- ✓ Frontal mounting cylinder bull horn type
- ✓ Universal compact cylinder
- ✓ Performance steering and easy installation



We recommend to order the steering system with SAE100R75/16 hose for installation on high performance engine.

Hydraulic steering system packaged in a box for outboard engine up to 80 hp, composed of: Helm pump, Cylinder, Fittings, fast connection filler tube kit, 1 lt hydraulic oil, 2 x 5 mt SAE 100R7 1/4 hoses with fittings pressed on one end.

It's possible to order hoses completely fitted on both ends

- **GM3-MRA** (see pag. 27)
helm pump capacity: 14 cc
Turns hd to hd: 5,2

HYDRAULIC STEERING SYSTEM

Hydraulic steering system kit up to 150 Hp



HYDRAULIC STEERING SYSTEM



GF. 150BRT



- ✓ Frontal mounting cylinder bull horn type
- ✓ Universal compact cylinder



We recommend to order the steering system with SAE100R75/16 hose for installation on high performance engine.

Hydraulic steering system packaged in a box for outboard engine up to 150 hp, composed of: Helm pump, Cylinder, Fittings, fast connection inner tube kit, 2 lt hydraulic oil, 2 x 6 mt SAE 100R7 1/4, hoses with fittings pressed on one end. Max speed: 40 knots. Best performance with engines up to 130 Hp. It's possible to order hoses completely fitted on both ends (see page 62)

- **GMO-MRA**
helm pump capacity 17 cc
with X.354 bezel kit
Turns hd to hd: 4,9



MC150BR

FRONTAL MOUNTING / BALANCED CYLINDER

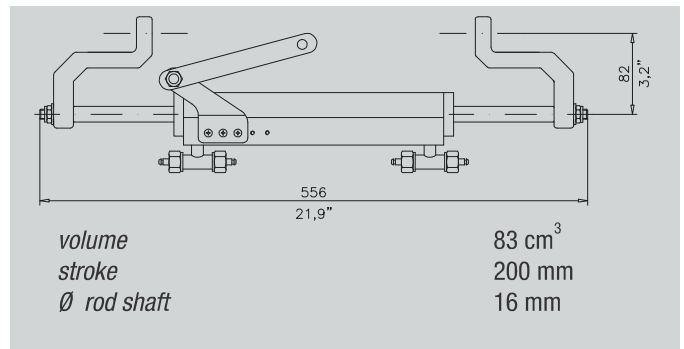

Support rod composed of two pieces for easy and fast installation, especially with reduced space condition on the splash well.

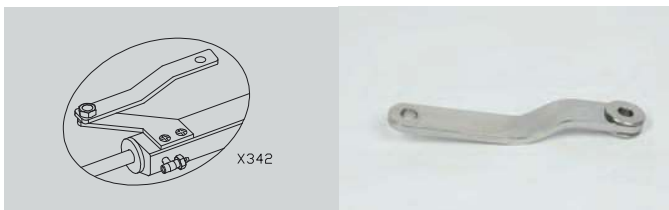

WARNING

Use kit X.342 for applications on Yamaha 40/50/60/70 Hp engines and Honda 115/130 Hp (discontinued type)

Hydraulic steering system kit up to 300 Hp



GF. 300AT

- ✓ Frontal mounting cylinder bull horn type
- ✓ Universal compact cylinder
- ✓ Performance steering and easy installation



Up to 300 hp or a couple of 300 hp (600 hp) engine with counter rotating propellers. All the systems are not intended for racing boat

Hydraulic steering system packaged in a box for outboard engine up to 300 hp, composed of: Helm pump, Cylinder, Fittings, fast connection filler tube kit, 2 lt hydraulic oil, 2 x 7,5 mt SAE 100R7 5/16 hoses with fittings pressed on one end.
It's possible to order hoses completely Fitted on both ends



- **GM2-MRA01**
helm pump capacity 27 cc
with X.343 bezel kit
(Specify when placing the order if round bezel kit X.353 is preferred)
Turns hd to hd: 5



MC300A
FRONTAL MOUNTING / BALANCED CYLINDER

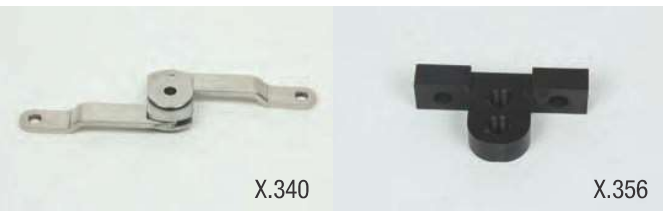
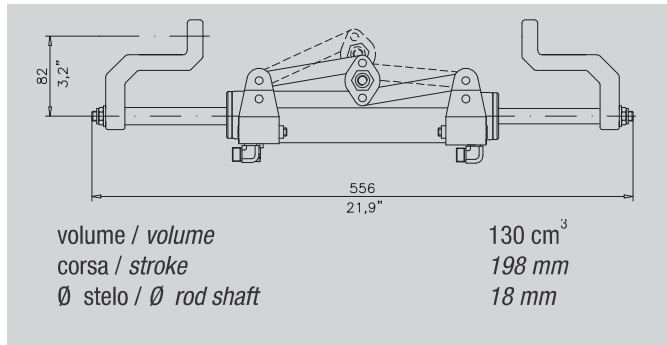

WARNING
Use kit X.340 for applications on Honda 115/130 Hp and kit X.356 for Mercury Optimax 115 Hp engines.

HYDRAULIC STEERING SYSTEM



REINFORCED STEERING!

NEW!
GF350HD
HEAVY DUTY - REINFORCED STEERING
DESIGNED FOR 300HP - 350HP OUTBOARD ENGINES



Hydraulic steering system kit up to 350 Hp



GF. 350HD

- ✓ Frontal mounting cylinder bull horn type
- ✓ Universal compact cylinder
- ✓ Performance steering and easy installation

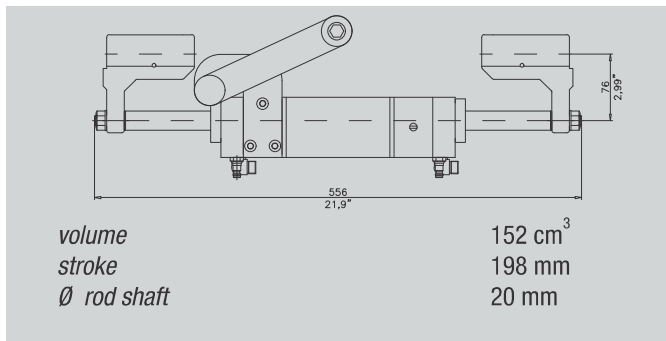

- **GM2-MRA01**
helm pump capacity 27 cc with X.343 bezel kit
(Specify when placing the order if round bezel kit X.353 is preferred)
Turns hd to hd: 5,6

Up to 350 hp or a couple of 350 hp (700 hp) engine with counter rotating propellers. All the systems are not intended for racing boat



MC300HD
FRONTAL MOUNTING / BALANCED CYLINDER

Hydraulic steering system packaged in a box for outboard engine up to 350 hp, composed of: Helm pump, Cylinder, Fittings, fast connection filler tube kit, 2 lt hydraulic oil, 2 x 7,5 mt SAE 100R7 5/16 hoses with fittings pressed on one end.
It's possible to order hoses completely fitted on both ends

Double engine application with MC350HD

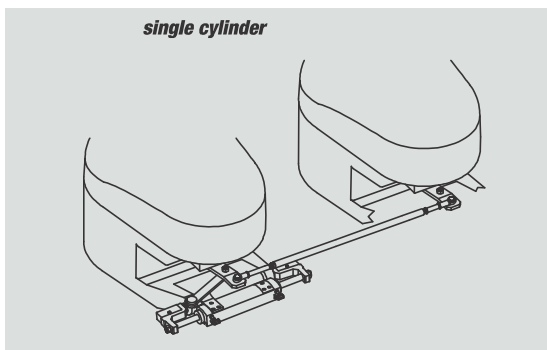

Art. 358.06
Tie bar

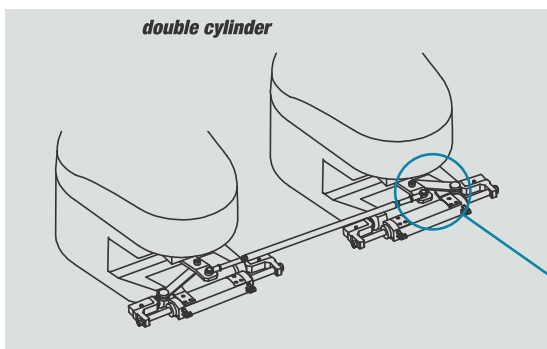

Art. 358.06
Tie bar

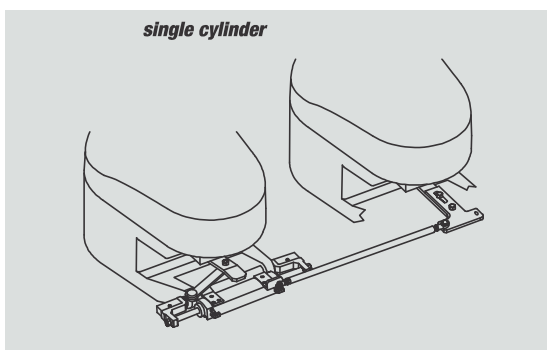

Order port cylinder
Art. MC350HD-2

Art. 358.08
Tie bar



Triple engine application with MC350HD

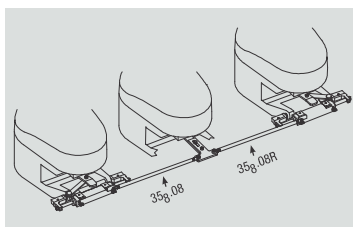

Application scheme



Art. MC350HD-2
Port cylinder

In the applications with dual MC350HD cylinder it is necessary to order a standard MC350HD cylinder (link arm attached to the starboard side of the cylinder) and a port cylinder (link arm attached to the port side of the cylinder, Art. MC350HD-2).

Art. 358.08
Tie bar



Art. 358.08R
Tie bar



Hydraulic steering system kit up to 150 Hp



GF. 150T

Lateral mounting cylinder for application where is not possible to install a balanced frontal cylinder.



Picture of installation on outboard engine

Hydraulic steering system packaged in a box for outboard engine up to 150 hp, composed of: Helm pump, Cylinder, Fittings, fast connection filler tube kit, 2 lt hydraulic oil, 2 x 7,5 mt SAE 100R7 5/16 hoses with fittings pressed on one end.
It's possible to order hoses completely fitted on both ends

GF. 150RT

- ✓ Frontal mounting cylinder bull horn type
- ✓ Performance steering and easy installation



Hydraulic steering system packaged in a box for outboard engine up to 150 hp, composed of: Helm pump, Cylinder, Fittings, fast connection filler tube kit, 2 lt hydraulic oil, 2 x 6 mt SAE 100R7 1/4 hoses with fittings pressed on one end
It's possible to order hoses completely fitted on both ends

Double cylinder hydraulic steering system kit



GF. 300AT2

- ✓ Frontal mounting cylinders bull horn type
- ✓ Universal compact cylinders
- ✓ Performance steering and easy installation

Up to a couple of 300 hp (600 hp) engines. All the systems are not intended for racing boat

Hydraulic steering system packaged in a box for outboard engines, composed of: Helm pump, Cylinder, Fittings, fast connection filler tube kit, 2 lt hydraulic oil, 2 x 7,5 mt SAE 100R7 5/16 hoses with fittings pressed on one end.
It's possible to order hoses completely fitted on both ends

Hydraulic steering system for special applications



GF. 300BVT EVOLUTION

- ✓ With extra stroke cylinder
- ✓ With fixed hoses

Up to 300 hp or a couple of 300 hp (600 hp) engine with counter rotating propellers. All the systems are not intended for racing boat

Hydraulic steering system packaged in a box for outboard engine up to 300, hp composed of: Helm pump, Cylinder, Fittings, fast connection filler tube kit, 2 lt hydraulic oil, 2 x 7,5 mt SAE 100R7 5/16 hoses with fittings pressed on one end.
It's possible to order hoses completely fitted on both ends

Inboard hydraulic steering systems



HYDRAULIC STEERING SYSTEM



GE30 for boats from 15 to 20 ft

GE50 for boats from 18 to 30 ft

GE75 for boats from 20 to 40 ft

GE100 for boats from 24 to 44 ft

Complete kit composed of:

- **Art. GE30**
 pump GM0-MRA
 bezel kit
 cylinder CE30
 ttings
 2 x 6 mt SAE 100R7 1/4
 1 lt hydraulic oil
 Turns hd to hd: 3,6
- **Art. GE50**
 pump GM2-MRA01
 bezel kit
 cylinder CE50
 ttings
 2 x 7,5 mt SAE 100R7 5/16
 2 lt hydraulic oil
 Turns hd to hd: 3,5
- **Art. GE75**
 pump GM2-MRA01
 bezel kit
 cylinder CE75
 ttings
 2 x 7,5 mt SAE 100R7 5/16
 2 lt hydraulic oil
 Turns hd to hd: 4,4
- **Art. GE100**
 pump GM2-MRA03
 bezel kit
 cylinder CE100
 ttings
 2 x 7,5 mt SAE 100R7 5/16
 2 lt hydraulic oil
 Turns hd to hd: 6,3

Inboard cylinders features



New line of inboard cylinders

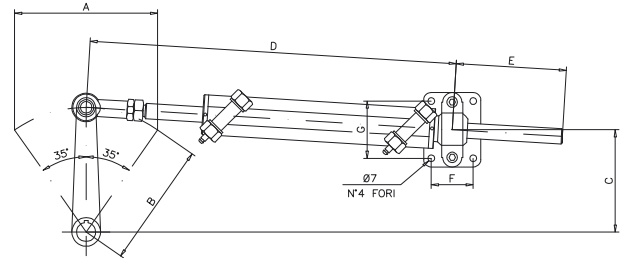

Article	A		B		C		D		E		F		G		Volume cm ³	Press bar	Stroke cm	Bore cm	Weight Kg
	mm	inches	mm	inches	mm	inches	mm	inches	mm	inches	mm	inches	mm	inches					
CE30	150	5.9	131	5.16	107	4.2	383	15.1	96	3.8	44	1.73	60	2.36	62	80	150	28	1,9
CE50	150	5.9	131	5.16	107	4.2	405	16	96	3.8	44	1.73	60	2.36	90	80	150	32	2,0
CE75	215	8.5	187	7.36	155	6.1	510	20.08	130	5.1	44	1.73	60	2.36	118	80	215	32	2,8
CE100	215	8.5	187	7.36	155	6.1	510	20.08	130	5.1	44	1.73	60	2.36	202	100	215	40	3,4

Kit composed of

Article	Pump	Cylinder	Max torque on 35°	Turn hd to hd
GE30	GM0-MRA	CE30	30	3,6
GE50	GM2-MRA01	CE50	50	3,5
GE75	GM2-MRA01	CE75	75	4,4
GE100	GM2-MRA03	CE100	100	6,3

Accessories for hydraulic steering systems



Part No.H-AP51

Hydraulic oil Mavimare (1lt)



Part No.X.371

Fill vent plug

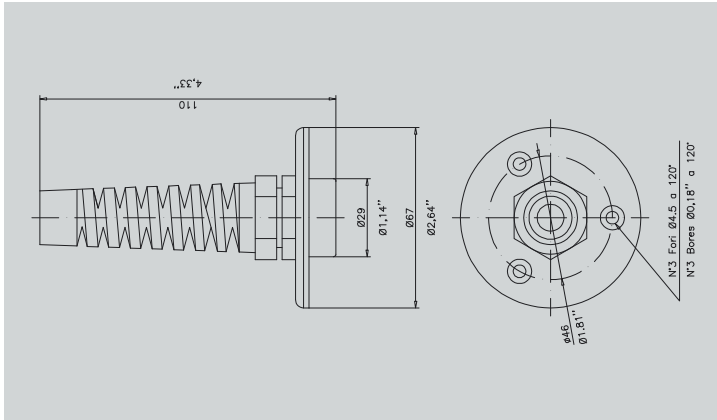

Part No.X.349

*Bulk head hose kit
composed of 1 pcs.*

Part No.X.374

*Kit passa paratia per tubo
idraulico doppio raccordato
dimensioni 106x89 mm*

Part No.X.374

*Bulkhead kit for dual hose with
preassembled fittings
dimensions 106x89 mm*



Part No.X.348

BULKHEAD FITTING KIT

*Kit composed of two stainless
steel 316 fittings to connect two
hose ends.*

Suitable for 5/16 and 1/4 hoses





Part No.V.AH35 Ø 350
Wheel in stainless steel
with mahogany handgrip.
See draw B



Part No.M.32 Ø 320
Nuovo modello in NAYLON
nero 4 razze.
vedi disegno M

Part No.M.32 Ø 320.
Steering wheel new model
black nylon 4 spokes.
See draw M

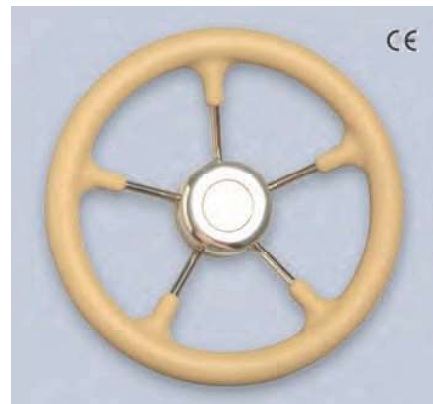

Part No. V.B32C Ø 320
poliurethane cream
See draw C



Part No.V.N32 Ø 320
Standard steering wheel
Naylon colour black.
See draw C



Part No.V.N32B Ø 320
Standard steering wheel
Naylon colour white.
See draw C



Part no.V.LN32 Ø 350
Steering wheel with
plastic grip.
See draw N



Part no.V.LA32B Ø 320
Steering wheel with black
plastic grip.
See draw L



Part no.V.FB35 Ø 350
Steering wheel with
handgrip in polyurethane,
aluminium spokes.
See draw G

Bollard



Stainless steel 316 bollards with baseplate

Part No.	DIAMETER	HEIGHT	WIDTH
MK184.18	50	95	130
MK184.19	60	120	160
MK184.20	70	142	180
MK184.21	80	172	200



Stainless steel 316 bollards for direct welding

Part No.	DIAMETER	HEIGHT	WIDTH
MK184.22	50	90	130
MK184.23	60	110	160
MK184.24	70	130	180
MK184.25	80	150	200



Racked bollards chromed brass

Part No. 185.18	30x40x100 mm
Part No. 185.19	40x50x140 mm
Part No. 185.20	40x65x175 mm
Part No. 185.21	50x80x200 mm



Racked bollards in s. s. AISI 316

Part No. 185.13	Lungh. 150 mm
Part No. 185.15	Lungh. 200 mm
Part No. 185.16	Lungh. 260 mm
Part No. 185.17	Lungh. 300 mm

HYDRAULIC STEERING

HYDRAULIC STEERING SYSTEM OUTBOARD

For boats with engines up to 150 HP. Helm pump made in aluminum, with non-return valve incorporated. Cylinder in aluminum and stainless steel, with breather valves. Completed with racors, rilsan tubing and 2L hydraulic oil.

TX4200K	
Pump mode	BayStar
helm volume	23 cm ³
Cylinder model	HC4645H
Cylinder volume	105 cm ³
Cylinder travel	206 mm
Turns lock to lock	5
Hose with racors	2 x 6 m
Max. speed	50 kn

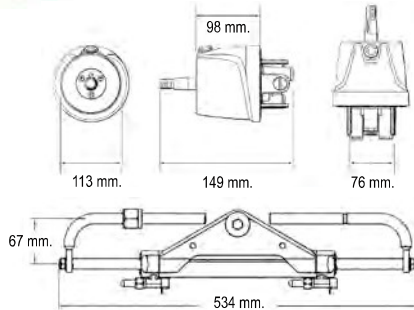

HYDRAULIC STEERING SYSTEM OUTBOARD

For boats with engines up to 300 HP. Helm pump made in aluminum, with non-return valve incorporated. Cylinder in aluminum and stainless steel, with breather valves. Completed with racors, rilsan tubing and 2L hydraulic oil.

TX6400K	
Pump mode	SeaStar
helm volume	27.8 cm ³
Cylinder model	HC5345H
Cylinder volume	139 cm ³
Cylinder travel	206 mm
Turns lock to lock	5
Hose with racors	2 x 7m
Max. speed	65 kn

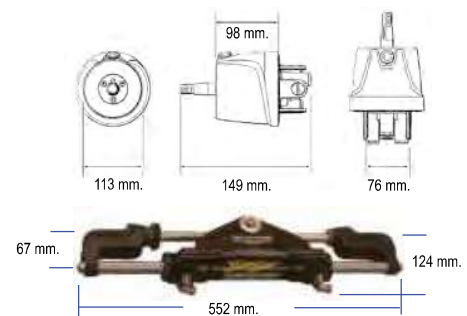

ACCESSORIES

LINK ARM

Link arm for outboards steering.
Stainless steel.

REF			
GS41080	Johnson/Evinrude	320 - 340 mm	1



Link arm for outboards steering.
Stainless steel.
Adjustable.
Quick connection.

REF			
GS41082		330 - 370 mm	1



Connector 7 pins. Without PowerTrim
 Dual function, single lever control.
 For outboard engines Yamaha and Parsun 9,9
 Electric to 30 Hp. Lever for neutral engine warm-up.
 For 33-C & 3300S cables

REF	OEM	MODELS	STROKE	YEAR
REC703-48230-14	703-48230-10	9.9 - 70 HP	2	1986+
	703-48230-11			
	703-48230-12			
	703-48230-13			
	703-48230-14			
	703-48230-15			
	703-48230-16			
	703-48230-17			
	703-48230-18			
	703-48230-1A			
	703-48230-20			
	703-48230-21			



TELEFLEX «SL3»

Dual function, single lever control, for virtually all stern drive, outboard and inboard engines. Push button for neutral engine warm-up. Neutral interlock prevents starting in gear. For cable 33-C and 3300S, OMC or Mercury.

REF	
MOR309476	Standard
MOR309478-002	With T-T switch

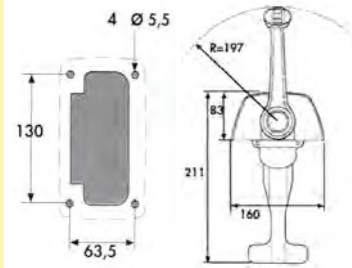

Connector 10 pins. Without PowerTrim
 Dual function, single lever control For outboard engines
 Yamaha and Parsun 40 to 250 Hp.
 Lever for neutral engine warm-up.
 With power trim switch and wires.
 For 33-C & 3300S cables

REF	OEM	MODELS	STROKE	YEAR
REC703-48205-16	703-48205-10	40-250 HP	2 & 4	1984+
	703-48205-11			
	703-48205-12			
	703-48205-13			
	703-48205-14			
	703-48205-15			
	703-48205-16			
	703-48205-17			
	703-48205-18			
	703-48205-1A			
	703-48205-1B			
	703-48205-20			
703-48205-21				



SIDE CONTROL

Single Lever Dual action side mount control designed for sail boats. Single lever throttle/gear Neutral safety switch option (prevents starting Uses 33-C and 3300C

REF
TX172103

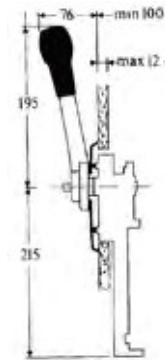

TC CONTROL

Chrome plated heavy duty single function control for clutch and throttle. With twisting brake on throttle handle. Uses 33-C and 3300C cables.

REF
MKI 36468

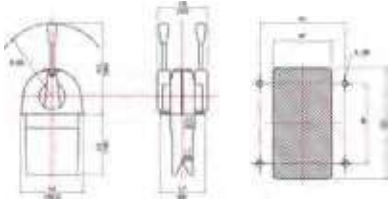

TS CONTROL

Chrome plated control for dual function by lever (clutch and throttle). Handle pulls out to operate neutral throttle. Neutral safety switch to ensure engine only starts when in neutral. Uses 33-C y 3300C cables.

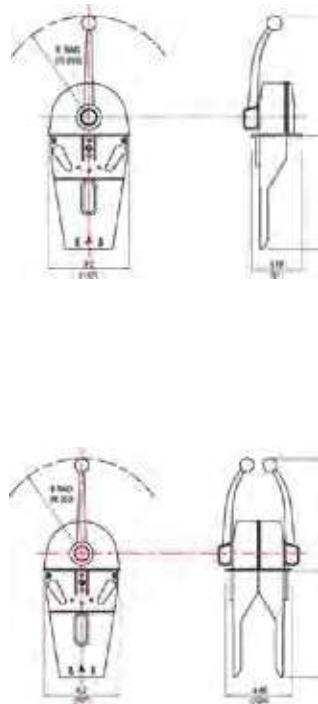

REF	HANDLE	ENGINE
MKI308601	1	1
MKI308602	2	2

ELECTRIC

ELECTRIC TRIM TAB KIT

For boats up to 54'. Contains: 2 actuators, 2 stainless steel trim plates and electric harness.
CONTROL SWITCH NOT INCLUDED

REF	TABS	
LEN15000	9 x 9" = 23 x 23 cm	14-18' = 4 - 5,5 m
LEN15001	9 x 12" = 23 x 30 cm	16-25' = 5 - 7,5 m
LEN15002	9 x 18" = 23 x 46 cm	22-30' = 6,5 - 9 m
LEN15007	12 x 12" = 30 x 30 cm	17-30' = 5,2-9,2 m
LEN15008	12 x 18" = 30 x 46 cm	26-36' = 8 -11 m
LEN15009	12 x 24" = 30 x 61 cm	30-44' = 9 -13 m
LEN15010	12 x 30" = 30 x 76 cm	34-54' = 10-16 m



ELECTRIC TRIM TAB KIT

Electric Trim tab kit for Extreme Duty boats.
Contains: 4 actuators, 2 stainless steel trim plates.
CONTROL SWITCH NOT INCLUDED

REF	TABS	
LEN15046	19 x 14" = 48 x 35 cm	34 - 54' = 10 - 16 m



SPARE PARTS TRIM

REF	TABS
LEN15054	Actuator
LEN15085	Upper mounting bracket
LEN50014	Lower mounting bracket
LEN15087	Mounting pin
LEN15086	Deutsch connector kit
LEN30142-1	Harness actuator 26'
LEN30142-2	Harness actuator 32'
LENPL909	Trim Plane 9" x 9"
LENPL912	Trim Plane 9" x 12"
LENPL918	Trim Plane 9" x 18"
LENPL1212	Trim Plane 12" x 12"
LENPL1218	Trim Plane 12" x 18"
LENPL1224	Trim Plane 12" x 24"
LENPL1230	Trim Plane 12" x 30"



ELECTRIC TRIM TAB KIT

Electric Trim tab kit for boats up to 30'.
Contains: 2 actuators, 2 stainless steel trim plates and electric harness.
CONTROL SWITCH NOT INCLUDED

REF	TABS	
LEN15041	12 x 12" = 30 x 30 cm	17-30' = 5 - 9 m



MANUAL BILGE PUMP

MANUAL BILGE PUMP

Hand suction pump. Manufactured in anti-corrosion plastic. Supplied with 80 cm plastic hose.

REF		
MKGS20020	55 cm	0,55 l/m
MKGS20021	75 cm	0,80 l/m



FOOT PUMP

Self priming and double action foot pump. Made of white plastic.

REF			
MKGS20146	Ø 14 mm	9.5 l/m	150 x 150 x 90 mm

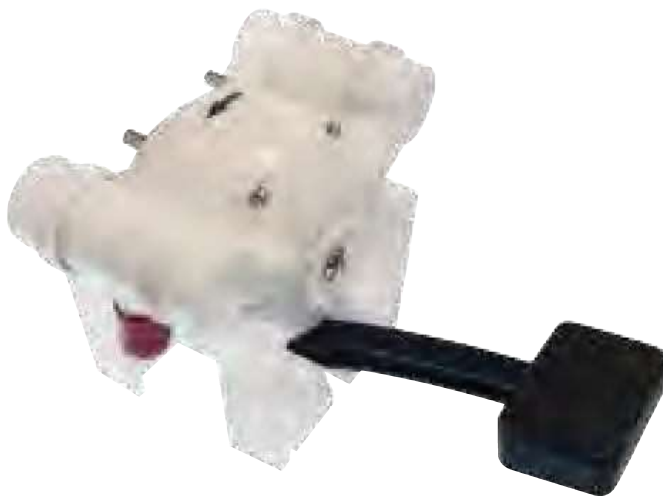

Plastic body and rubber diaphragm.

REF			
SFDHPG72001	Ø 32 mm / 1-1/4"	Ø 38 mm / 1-1/2"	45 l/m
SFDHSG72001	Ø 32 mm / 1-1/4"	Ø 38 mm / 1-1/2"	45 l/m



SPARE DIAPHRAGM

REF
SFDHPSP



Manual bilge pump. Plastic body and rubber diaphragm.

REF		
MKGS20030	Ø 25 mm / 1"	30 l/m

SPARE DIAPHRAGM





REF
MKGS20031



BILGE PUMP



Laguna bilge pumps are equipped with a built-in electrically controlled snap switch making it fully automatic. No float switch needed and no power used until pump turns on when water level rises. These pumps are durable and easy to install, and they offer boaters a sleek new design that has been tested to be reliable, efficient, and automatic operative in harsh saltwater and freshwater uses. Equipped with stainless steel shaft 316, and high-impact durable plastic housing. New blister packaging available with moq 100 pcs per articles.

Part No.			Flow/ Mln	Flow 1 MT / Mln		 (mm)
MK5700205115	500 GPH	12V (1,8 A)	32	25	19 mm	151x78x95 mm
MK5700205133	750 GPH	12V (2,7 A)	50	42	19 mm	151x78x95 mm
MK5700205134	750 GPH	24V (1,5 A)	50	42	19 mm	151x78x95 mm
MK5700205021	1100 GPH	12V (4 A)	75	65	29 mm	151x78x95 mm
MK5700205022	1100 GPH	24V (2,5 A)	75	65	29 mm	151x78x95 mm





HEAVY DUTY BILGE PUMP



New heavy duty series of marine submersible bilge pumps. These pumps are durable and easy to install, and they offer boaters a sleek new design that has been tested to be reliable and efficient, both in harsh saltwater and freshwater uses. Equipped with stainless steel shaft, double ball bearing motor and mechanical seal, high impact durable plastic housing.

- Liquid cooled for extended motor life.
- Removable check valve included
- Heavy duty, AISI 316 steel shaft, double ball bearing motor
- Quality engineered mechanical seal on 2200 gph version.
- Automatic operation with optional float switch
- Complies with ISO 8848, EN 55014 Marine
- Easily interchangeable with most similar Bilge pumps (New upgraded base screen)





Part No.			Flow/ Mln	Flow 1 MT / Mln		 (mm)	Seal	Non Return Valve
MK5500000142	1750 GPH	12V (8 A)	110	85	1"1/4 1" 1/2	170x158x130d. mm	MECHANICAL	Yes
MK5500000144	1750 GPH	24V (4 A)	110	85	1"1/4 1" 1/2	170x158x130d. mm	MECHANICAL	Yes
MK5500000162	2250 GPH	12V (12 A)	140	120	1"1/4 1" 1/2	170x158x130d. mm	MECHANICAL	Yes
MK5500000164	2250 GPH	24V (6 A)	140	120	1"1/4 1" 1/2	170x158x130d. mm	MECHANICAL	Yes

MARINE PUMPS FOR DECKWASH, BILGE & REFUELLING



DECK PUMPS:

Ideal for deck washing, bilge pumping and pressurized systems Self priming up to 3/5 mt. vertical lift. All versions available upon request with super nitrile impeller.

Part No.	MOD		FLOW/LPM	FLOW 2 MT HEAD / LPM	CONNECTION IN/OUT	PUMP BODY	 (mm)
MK8500001112	ECO DECK PUMP	12V (8A)	30	23	19 mm.	THERMO-POLYMER	160x120x90
MK8500001124	ECO DECK PUMP	24V (4A)	30	23	19 mm	THERMO-POLYMER	160x120x90
MK8500000112	BRASS DECK PUMP	12V (8A)	35	28	1/2" 19 mm	BRASS	160x120x90
MK8500000124	BRASS DECK PUMP	24V (4A)	35	28	1/2" 19 mm	BRASS	160x120x90
MK8500000212	MAXI DECK PUMP	12V (12A)	45	39	1/2" 19 mm	BRASS	180x120x90
MK8500000224	MAXI DECK PUMP	24V (6V)	45	39	1/2" 19 mm	BRASS	180x120x90

GEAR AND OIL CHANGER PUMP:





Self priming electric gear pump particularly suitable for the transfer of oil, diesel, antifreeze, water and viscous liquids.

Available in different configurations:

Single pump intermittance use with or without hoses kit, Single pump continuous use with or without hoses kit





New with watertight continuous running motor for the transfer and supply of gasoil, oil and water. Fitted with Carling ON/OFF/ON built-in watertight switch. It comes with: 13-mm drain hose, 2 x rilsan hoses (6 mm and 8 mm) for the engine housing, 1.5-m cable with clamps for the battery pack.

Part No.		Flow/ LPM	CONTINUOUS DUTY	CONNECTION IN/OUT	HOSE KIT	 (mm)
MK8500000312	12V (4A)	8	NO	3/8" 13 IN/OUT	NO	140X80 mm
MK8500000324	24V (2,5A)	8	NO	3/8" 13 IN/OUT	NO	140X80 mm
MK8500010312	12V (4,5 A)	*	NO	3/8" 13 IN/OUT	YES	140X80 mm
MK8500000512	12V (6 A)	12	YES	3/8" 13 IN/OUT	NO	140X90 mm
MK8500000524	24V (3 A)	12	YES	3/8" 13 IN/OUT	NO	140X90 mm
MK8500010512	12V (6V)	*	YES	3/8" 13 IN/OUT	YES	140X90 mm
MK8500010524	24V (3V)	*	YES	3/8" 13 IN/OUT	YES	140X90 mm
MK8500010512N	12V (6V)	*	YES	3/8" 13 IN/OUT	YES	205X90 mm
MK8500010524N	24V (3V)	*	YES	3/8" 13 IN/OUT	YES	205X90 mm

GREY & BLACK DIAPHRAGM WATER PUMPS



A modern diaphragm pump that can be set up in several applications and with different pump motor configurations. It is easy to install as a bilge pump in any leisure craft or anywhere after the drain outlet in the waste water system or directly in the Matromarine waste water tank. No filters required, the pump can run dry, and can also handle a mixture of air and water without difficulty. Perfect for installation in tight spaces, the Laguna shower drain pump can be incorporated into a small boat bilge space. Available in version with double 19/25 mm port connection and 38 mm port connection. 38 mm version is equipped with straight and 360 degrees angled rotational port connection.

Part No.			Flow LPM / Min	Flow LPM 1,5 MT		 (mm)
MK8700101112	12V (4,5 A)		22	18	19-25 (GREY)	305x195x125mm
MK8700101124	24V (2,5 A)		22	18	19-25 (GREY)	305x195x125mm
MK8700001112	12V (6 A)		32	26	38 (WASTE)	355x195x125mm
MK8700001124	24V (3 A)		32	26	38 (WASTE)	355x195x125mm

MACERATOR PUMP





Macerator with stainless steel or brass internal pump body or brass and rubber impeller discharge pump

- self priming up to 2 mt. vertical lift.
- 43 LPM output and max 4 mt. total head
- macerates and discharges water and waste mixtures.

MAXI MACERATOR PUMP



Toilet waste macerator pump, 47 min. rated, can discharge tanks up to 2100 litres. Bronze pump body total head up to 5 mt. vertical lift.

Part No.			Flow/ Min	Flow 1 MT / Min	CONNECTION IN/OUT	PUMP BODY	 (mm)
MK5500001112	12V (12A)		43 LPM	23 LPM	38 HOSE BARB1 1/2"/25 MM.	THERMO-POLYMER/S.S.	240X130X90mm
MK5500001124	24V (7A)		43 LPM	23 LPM	38 HOSE BARB1 1/2"/25 MM.	THERMO-POLYMER/S.S.	240x130X90mm
MK5500000912	12V (12 A)		43 LPM	23 LPM	38 HOSE BARB1 1/2"/25 MM.	BRONZE	240X130X90mm
MK5500000824	24V (7 A)		43 LPM	23 LPM	38 HOSE BARB1 1/2"/25 MM.	BRONZE	240x130X90mm
MK5500001012	12V (14 A)		47 LPM	33 LPM	38 HOSE BARB1 1/2"/25 MM.	BRONZE	270X130X90mm
MK5500001024	24V (8V)		47 LPM	33 LPM	38 HOSE BARB1 1/2"/25 MM.	BRONZE	270x130X90mm

NAVAL BRONZE



BRONZE VALVE & SEA WATER SCOOP

new

BALL VALVE IN BRONZE

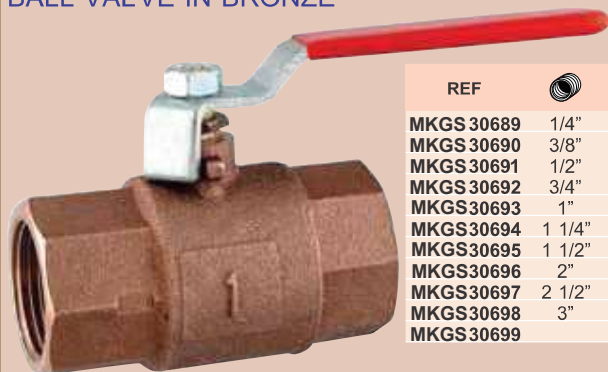

REF	SIZE
MKGS 30689	1/4"
MKGS 30690	3/8"
MKGS 30691	1/2"
MKGS 30692	3/4"
MKGS 30693	1"
MKGS 30694	1 1/4"
MKGS 30695	1 1/2"
MKGS 30696	2"
MKGS 30697	2 1/2"
MKGS 30698	3"
MKGS 30699	

90° PIPE ELBOW FEMALE/FEMALE IN BRONZE

REF	SIZE
MKGS 30650	3/8"
MKGS 30651	1/2"
MKGS 30652	3/4"
MKGS 30653	1"
MKGS 30654	1 1/4"
MKGS 30655	1 1/2"
MKGS 30656	2"
MKGS 30657	2 1/2"
MKGS 30658	3"
MKGS 30659	4"



MALE HOSE IN BRONZE

REF	SIZE	LENGTH
MKGS 30680	3/4"	20
MKGS 30681	1"	25
MKGS 30682	1"	30
MKGS 30683	1 1/4"	30
MKGS 30684	1 1/4"	35
MKGS 30685	1 1/4"	38
MKGS 30686	1 1/2"	38
MKGS 30687	1 1/2"	45
MKGS 30688	2"	50



90° PIPE ELBOW MALE/FEMALE IN BRONZE

REF	SIZE
MKGS 30660	3/8"
MKGS 30661	1/2"
MKGS 30662	3/4"
MKGS 30663	1"
MKGS 30664	1 1/4"
MKGS 30665	1 1/2"
MKGS 30666	2"
MKGS 30667	2 1/2"
MKGS 30668	3"
MKGS 30669	4"



CONNECTION NIPPLE IN BRONZE

REF	SIZE
MKGS 30633	3/8"
MKGS 30634	1/2"
MKGS 30635	3/4"
MKGS 30636	1"
MKGS 30637	1 1/4"
MKGS 30638	1 1/2"
MKGS 30639	2"
MKGS 30640	2 1/2"
MKGS 30641	3"



STRAINER INTAKE THRU HULL IN BRONZE

REF	SIZE
MKGS 30600	1/2"
MKGS 30601	3/4"
MKGS 30602	1"
MKGS 30603	1 1/4"
MKGS 30604	1 1/2"
MKGS 30605	2"



MALE PLUG IN BRONZE

REF	SIZE
MKGS 30642	3/8"
MKGS 30643	1/2"
MKGS 30644	3/4"
MKGS 30645	1"
MKGS 30646	1 1/4"
MKGS 30647	1 1/2"
MKGS 30648	2"
MKGS 30649	2 1/2"



STRAINER INTAKE THRU HULL HIGH FLOW IN BRONZE

REF	SIZE
MKGS 30606	2 1/2"
MKGS 30607	3"
MKGS 30608	4"

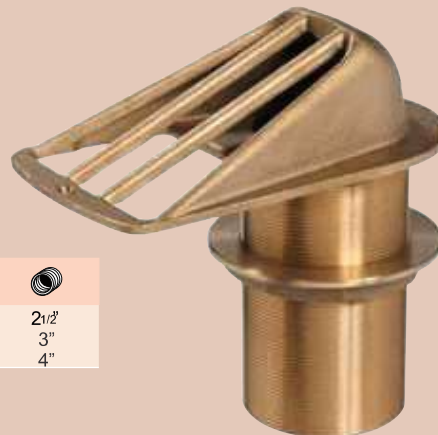



RACOR T IN BRONZE

REF	SIZE
MKGS 30670	3/8"
MKGS 30671	1/2"
MKGS 30672	3/4"
MKGS 30673	1"
MKGS 30674	1 1/4"
MKGS 30675	1 1/2"
MKGS 30676	2"
MKGS 30677	2 1/2"
MKGS 30678	3"
MKGS 30679	





new

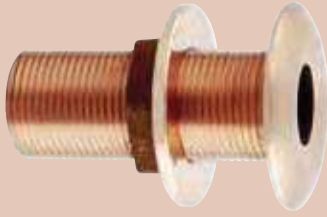

THRU HULL SCUPPER IN BRONZE

REF		 (cm)
MKGS30609	1/2"	6,30
MKGS30610	3/4"	7,10
MKGS30611	1"	7,60
MKGS30612	1 1/4"	8,15
MKGS30613	1 1/2"	8,45
MKGS30614	2"	10,00
MKGS30615	2 1/2"	13,20
MKGS30616	3"	16,00
MKGS30617	4"	20,90

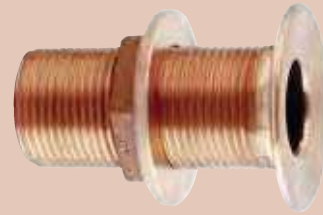

REF		 (cm)
MKGS30618	1/2"	6,20
MKGS30619	3/4"	7,10
MKGS30620	1"	7,60
MKGS30621	1 1/4"	8,15
MKGS30622	1 1/2"	8,30
MKGS30623	2"	10,00
MKGS30624	2 1/2"	13,00
MKGS30625	3"	15,85
30626	4"	MKGS 21,00



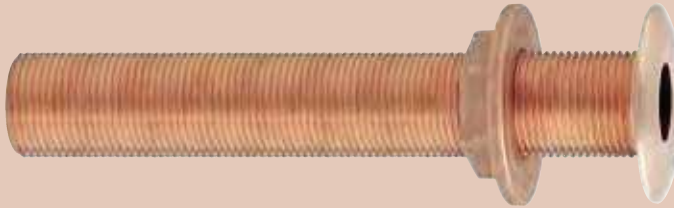

REF		 (cm)
MKGS30627	1"	24,00
MKGS30628	1 1/4"	24,00
MKGS30629	1 1/2"	24,00
MKGS30630	2"	24,00
MKGS30631	2 1/2"	24,00
MKGS30632	3"	24,00



SCOOP STRAINER

Manufactured in brass.

REF		
MKGS30369	270 x 200 mm	1



REF	Ø	
MKGS30376	60 mm	1
MKGS30377	80 mm	1
MKGS30378	100 mm	1
MKGS30379	120 mm	1



DRAIN GRATE 90°

Stainless steel 316 with 90° adapter for hose.

REF	A (mm)	B (mm)	C (mm)	D (mm)	
MKGS30305	25	15	36	42	1
MKGS30306	32	18	50	70	1
MKGS30307	38	18	50	70	1



DRAIN GRATE 45°

Stainless steel 316 with 45° adapter for hose.

REF	Ø	EXT	
MKGS30335	92 mm	35 mm	1



STALON COCKPIT DRAIN

Manufactured in nylon (66-30%) glass filled body and S.S.316 stamped face.

REF	A (mm)	B (mm)	C (mm)	D (mm)	E (mm)	
MKGS30338	38	45	60	128	55	1
MKGS30339	51	45	60	128	55	1

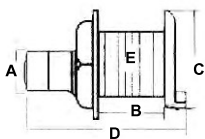



MarineKart[®]

Marine Accessories & Steering System

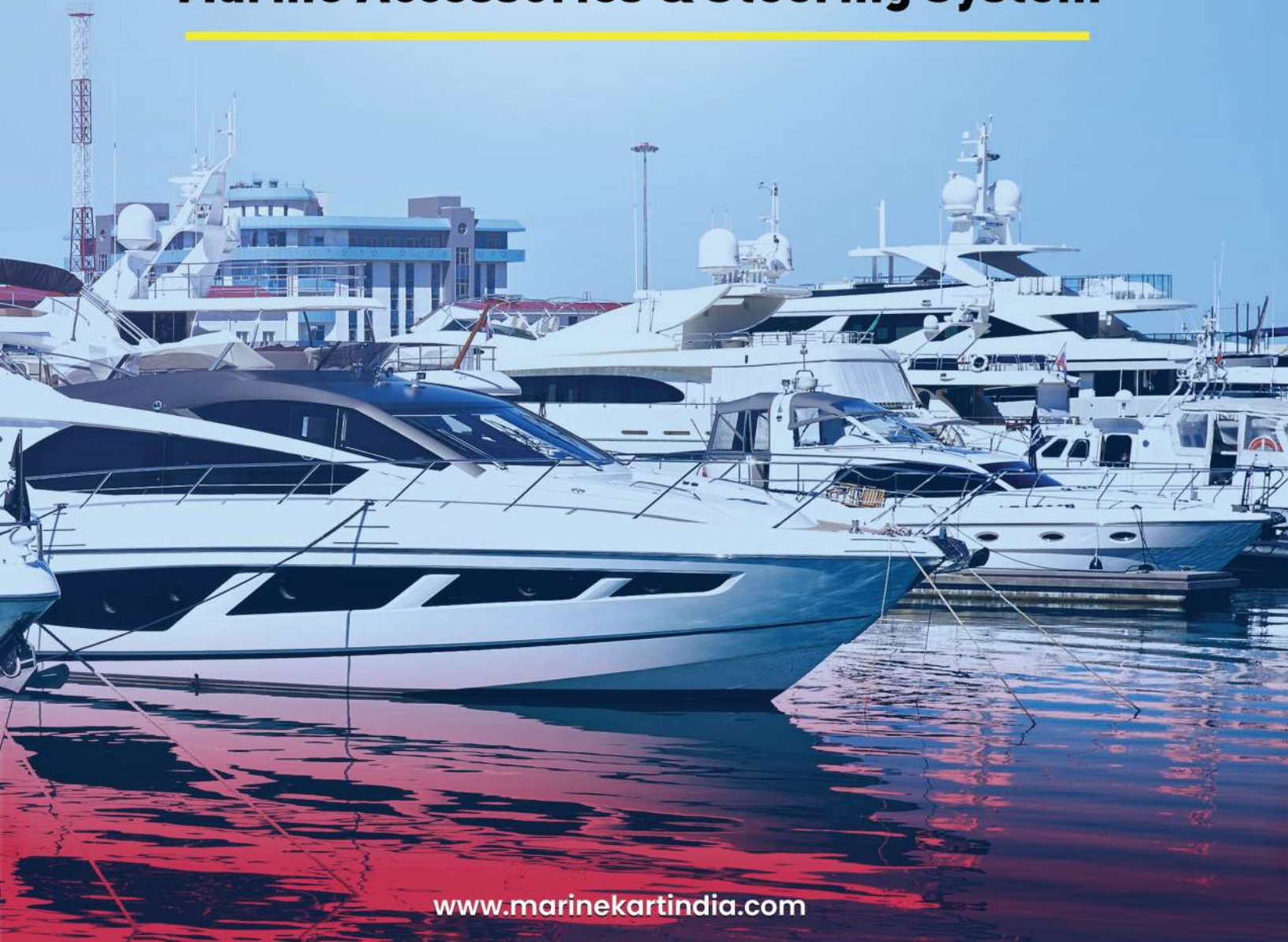

THRU HULL

new



REF	Ø	H (mm)	D (mm)	D1 (mm)	d (mm)	d1 (mm)	di (mm)
MKGS1062501	5/8"	73.5	42	17	23.5	16	10
MKGS1075001	3/4"	80	50.5	19	27	19	11.5
MKGS1100001	1"	93	61	26	33	25.5	18
MKGS1125001	1 1/4"	97	67.5	33	41	32	24
MKGS1150001	1 1/2"	102	75	47	46.5	38.5	28

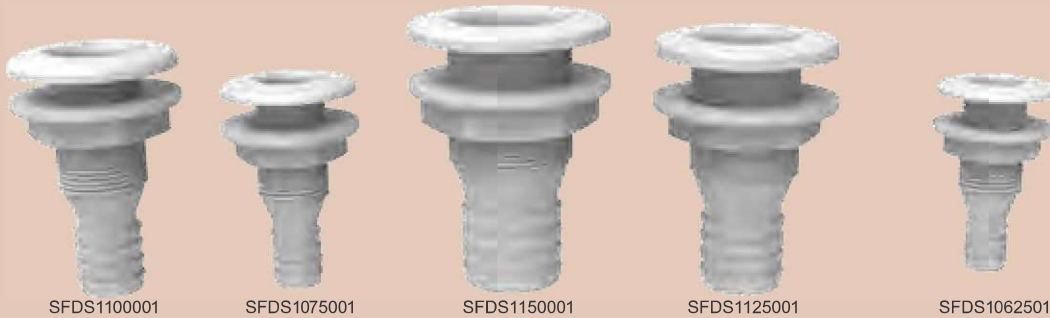
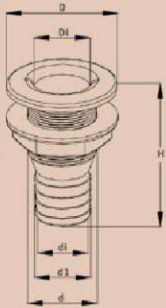

THRU HULL SCUPPER

Stainless steel 316.

REF	Ø	Icon	Icon
MKGS30208	3/8"	1	1
MKGS30209	1/2"	1	1
MKGS30210	3/4"	1	1
MKGS30211	1"	1	1
MKGS30212	1 1/4"	1	1
MKGS30213	1 1/2"	1	1
MKGS30214	2"	1	1



REF	Ø	Icon	Icon
MKGS30370	3/8"	1	1
MKGS30371	1/2"	1	1
MKGS30372	3/4"	1	1
MKGS30373	1"	1	1
MKGS30374	1 1/4"	1	1
MKGS30375	1 1/2"	1	1



REF	Ø	Icon	Icon
MKGS30215	3/8"	15 mm	1
MKGS30216	1/2"	19 mm	1
MKGS30217	3/4"	25 mm	1
MKGS30218	1"	30 mm	1
MKGS30219	1 1/4"	39 mm	1
MKGS30220	1 1/2"	45 mm	1



Manufactured in reinforced nylon with a S.S. 316 stamped face.

REF	Ø	A (mm)	B (mm)	C (mm)	D (mm)	E (mm)	Icon
MKGS30343	3/4"	19	86	33	48	28	1
MKGS30344	1"	26	86	33	48	28	1
MKGS30345	1 1/4"	32	103	41	60	33	1
MKGS30346	1 1/2"	38	103	41	60	33	1
MKGS30347	2"	52	130	56	82	46	1



Chrome plated plastic. For above waterline use.

REF	Ø	Icon
THTH-750CP	19 mm 3/4"	1
THTH-1200CP	29 mm 1 1/8"	1



90° THRU HULL

Chrome plated plastic. For above waterline use.

REF	Ø	Icon
THTH-7590CP	19 mm 3/4"	1
THTH-1290CP	29 mm 1 1/8"	1



BRONZE VALVE & SEA WATER SCOOP

THRU HULL SCUPPER

Manufactured in stainless steel AISI 316 with a PVC flapper valve.

REF		
MKGS30332	38 mm 1 1/2"	1



REF	Ø	A (mm)	B (mm)	C (mm)	D (mm)	
MKGS30333	1 1/2"	38	106	55	35	1

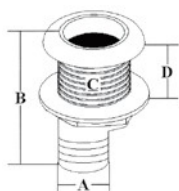

STRAINER INTAKE THRU HULL

Manufactured in stainless steel AISI 316

REF	A	B (mm)	C (mm)	D (mm)	
MKGS30245	1"	62	98	73	1
MKGS30246	1 1/4"	85	120	89	1
MKGS30247	1 1/2"	85	120	89	1

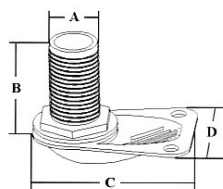

REF		
MKGS30200	3/8"	1
MKGS30201	1/2"	1
MKGS30202	3/4"	1
MKGS30203	1"	1
MKGS30204	1 1/4"	1
MKGS30205	1 1/2"	1
MKGS30206	2"	1
MKGS30207	2 1/2"	1
MKGS30221	3"	1

Manufactured in brass.

REF		
MKGS30021	1/2"	1
MKGS30022	3/4"	1
MKGS30023	1"	1
MKGS30024	1 1/4"	1
MKGS30025	1 1/2"	1
MKGS30026	2"	1
MKGS30027	2 1/2"	1
MKGS30028	3"	1



ENGINE MOUNT

ENGINE MOUNT

Manufactured in metal and vulcanized neoprene.

REF	MAX. (kg)	(mm)	(mm)	(mm)	(mm)
MKGS38100	100	14	98	44	62
MKGS38101	100	16	98	60	62



TIPO YANMAR

REF	MAX. (kg)	MAX. (lb)	(mm)	(mm)	(mm)	(mm)
MKGS38120	40	88	M16	173	205	145
MKGS38107	75	165				
MKGS38108	100	220				
MKGS38121	150	330				

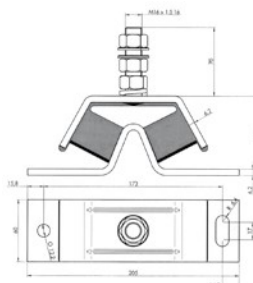

RAW WATER STRAINER & ACCESSORIES

RAW WATER STRAINER

Made of plastic with transparent cover for easy inspection.

REF	MAX. (kg)	MAX. (lb)				
			(mm)	(mm)	(mm)	(mm)
MKGS38103	55	120	M12	100	120	112
MKGS38104	160	355	M16	140	183	133
MKGS38123	160	355	3/4	140	183	133



REF				
			(mm)	
MKGS30385	150 l/h	3/4"	115 x 127	1
MKGS30386	250 l/h	1"	165 x 165	1
MKGS30387	300 l/h	1 1/4"	165 x 165	1
MKGS30388	300 l/h	1 1/2"	165 x 165	1



REF				
			(mm)	
MKGS30380	150 l/h	3/4"	145 x 80	1
MKGS30381	300 l/h	1 1/2"	145 x 150	1

REF	MAX. (kg)	MAX. (lb)			
			(mm)	(mm)	(mm)
MKGS38106	55	120	105	140	40



TIPO MERCURISER

REF	OEM	MAX. (kg)	MAX. (lb)				
				(mm)	(mm)	(mm)	(mm)
MKGS38122	35852	135	300	5/8" - 16	4"	5 1/4"	5"
MKGS38105	814263A1	135	300	3/4" - 19	4"	5 1/4"	5"



MOTOR FLUSHER ROUND

For use on most outboards and inboard/outboards engines with side water inlets.

REF	
MKGS30352	1



MOTOR FLUSHER SQUARE

Heavy duty motor flusher for use on most outboards and inboard/outboards engines with side water inlets.

REF	
MKGS30353	1

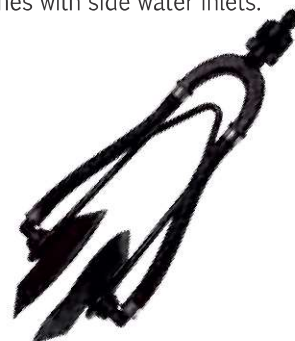

FUEL TANK

Portable fuel tank made of ELTEX 90% filling with security plug..

ISO-13591 ABYC H-25 International Standards Certified

REF	(l)	(mm)	(cm)
MKGS31050	12	8	26 x 46 x 22
MKGS31051	22	8	32 x 54 x 24
MKGS31053	30	8	36 x 50 x 24
MKGS31052	22	8	32 x 50 x 21



MKGS31052
With built-in level indicator.

REF	(l)	(mm)	(cm)
MKGS31047	42	8	22 x 35 x 65
MKGS31048	52	8	22 x 35 x 80
MKGS31049	75	8	22 x 35 x 105
MKGS31043	45	8	30 x 35 x 50
MKGS31044	60	8	30 x 35 x 65
MKGS31045	75	8	30 x 35 x 80
MKGS31046	100	8	30 x 35 x 105



ACCESSORIES FOR GS31043 TO GS31049

REF	
MKGS31056	Outlet pipe
MKGS31058	Compleat outlet
MKGS31055	Complete plug
MKGS31057	Breather pipe for Diesel



WATER TANK

Fresh water tank made of polyethylene. With pick up racor 8mm, vent and 5 holes for pre-drilled level sensor.

REF	(l)	(cm)	(cm)	(cm)
MKGS31229	42	22	35	65
MKGS31230	52	22	35	80
MKGS31231	75	22	35	105
MKGS31225	45	30	35	50
MKGS31226	60	30	35	80
MKGS31227	75	30	35	80
MKGS31228	100	30	35	105



WASTE TANK



Holding tanks for waste waters with macerator pump integrated. Manufactured in blue polyethylene, according with ISO 8099 regulations. Complete with dead female unions for lateral connectors and inspection cover.

REF	(l)	(V)	(cm)
MKGS50046	56	12 V	45 x 40 x 35
MKGS50039	56	24 V	45 x 40 x 35





FUEL CONNECTOR



TANK CONNECTOR

REF	OEM	ENGINES		
MKGS31038	65720-94411	SUZUKI OLD		1
MKGS31039		stroke		





REF	OEM	ENGINES		
MKGS31026	22-142131		1/4"	1
MKGS31027	22-13563T-3	MERCURY/MARINER	5/16"	1
MKGS31028	22-13563T-3		3/8"	1





REF	OEM	ENGINES		
MKGS31074	6Y1-24305-04		1/4"	1
MKREC6G1-24305-03	6G1-24305-00	YAMAHA	5/16"	1
MKGS31076	6E5-24305-05		3/8"	1



DOUBLE CONNECTOR

REF	ENGINES		
MKGS31091	OMC	8 mm	1
MKGS31092	YAMAHA	8 mm	1
MKGS31093	MERCURY/MARINER	8 mm	1





REF	OEM	ENGINES		
MKGS31082	22-13563T 7	MERCURY/MARINER 4HP - V6 (1998+)	3/8"	1





PRIMER BULB

PUMP

Premium quality bulb resistance to alcohol as well as UV and ozone.

REF	OEM	ENGINES		
SIE18-8004	98396A38 174511	MERCURY/MARINER JOHNSON/EVINRUDE	5/16"	1
SIE18-8005	98396A38 174511	MERCURY/MARINER JOHNSON/EVINRUDE	3/8"	1







REF	OEM	ENGINES		
MKGS31034	17650-921-003ZB	HONDA	3/8"	1



FUEL LINE ASSEMBLY

Universal. With 2 m alcohol resistant hose.

REF		
MKGS31096	5/16"	1
MKGS31097	3/8"	1
MKGS31099	8 mm	1
SIE18-8013	5/16"	1
SIE18-8015	3/8"	1
CEF500600	8 mm	1

REF		
MKGS31187	1/4"	1
MKGS31090	5/16"	1
MKGS31095	3/8"	1
CEF500621	8 mm	1



MKGS31097



MKGS31096



MKCEF500621



MKGS 31099



SIE18-8013
SIE18-8015

CEF500600



MKGS31187 - MKGS31090 - MKGS31095



IMPELLERS

INBOARD

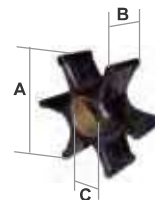

REF	CEF	A (mm)	B (mm)	C (mm)	BLADE KEY TYPE		JABSCO	JOHNSON	SHERWOOD	VETUS	VOLVO	YANMAR	MERCUISER
MKREC3586494	500100	40	19,2	9,5	6	I	4528-0001	09-806B	9979K	501	803729 875807-0 3586494	104211-42070	
MKREC653-0001	500101	51	22	12	6	I	653-0001 18653-0001	09-810B		801		128990-42200	
MKREC4598-0001	500102	65	51	16	8	J	4598-0001 4599-0101		10187K 12338K		818680 818680 14320/620		
MKREC3854286	500103	62	31,8	16	12	J	18838-0001	09-701B-1	09959K		835512 3854286		
MKREC22120-0001	500104	57	50	16	12	K	22120-0001				876120-7 834794 875736		
MKREC836-0001	500105	95	63	25	9	K	836-0001	09-1029B		901	2430184 875660 807904 877061		
MKREC3841697	500106	65	50	16	8	K	920-0001	09-1028B	18200K	301	875593 3841697 3862281	127610-42200	34765A1
MKREC21213660	500107	57	31,5	16	12	K	1210-0001 3085-0001	09-1027B		201	875811-2 877400	129470-42351	
MKREC1411-0001	500113	31,3	12	8	6	H	1411-0001 21414-0001 14792-0001					128176-42071	
MKREC17937-0001	500114	65	50	16	10	K	17937-0001	1028B	18200		3588475 877061 801277		
MKREC6760-0001	500115	95	88,5	25	9	K	6760-0001	09-802B			844683 875808		
MKREC3593659	500116	51	22	12,7	6	I	673-0001	09-1026B		IMP 00901	3593659 3596497 22222936		47-810567
MKREC10615K	500120	65	41,5	16	12	J	18948-0001	09-702B	10615K		835874 875583		
MKREC3586496	500121	40	19,2	12	6	I	22405-0001	09-808B 09-45589		601	833995 21951342 3586496		
MKREC13554-0001	500124	57	48,2	16	12	K	13554-0001	09-812B				119773-42600-01	
MKREC22779-0001	500129	51	22	12,7	6	J	22799-0001			101		124223-42090	
MKREC18777-0001	500133	57	50	16	10	K	18777-0001						
MKREC21730344	500135	95	63	25	12	k	17935-0001	09-819B			877066 21951362		
MKREC6303-0001	500138	51	22	8	6	H	6303-0001	09-824P					
MKREC875697	500145	95	88,5	25	12	K	17936-0001 21676-0001	09-814B			875814 875697 219513644 845796 844683 842857	16500-32570	
MKREC17370-0001	500152	95	88,5	25	12	M	17370-0001						
MKREC18786-0001	500153	117,6	88,9	25	9	M	18786-0001						
MKREC47-809866T	500161	65	68	16	10	K	31130-0061					119593-42200	47-831311350 47-89866T
MKREC3887761	500162	65	80	25	12			09-821B			21951358 3887761	119574-42550	
MKREC17000K	500164	82,5	73,5	20	12	J	18958-0001		17000K				
MKREC09000K	500165	62	22	16	12	J			9000K			128620-42201	
MKREC10077K	500166	57	20	12,7	12	J			10077K				
MKREC15000K	500167	65	51	16	12	J	18327-0001		15000K				
MKREC875575	500170	57	31,5	16	12	J	4568-0001	09-801B			875575 21951350 831182	145410-46090 124310-46090	
MKREC3593573	500177	65	76	16	8	K	17018-0001B				3583602 3593573 3588476 38.194.86		
MKREC21213664	500178G												
MKREC22000K	500179	114	109	25	10	K			22000K				
MKREC27000K	500181	82,5	73,5	20	12	k			27000K				
MKREC18000K	500182	95	102	25	12	K			18000K				
MKREC09-820B	500186	95	130	25	12	K		09-820B					
MKREC08000K	500190	40	19,2	12	6	H			8000K				
MKREC29000K	500192	95	102	25	12	K			29000K				
MKREC653-0001	500201	51	22	12	6	I	653-0003 4528-0003 23099-0003	09-810B-9					
MKREC3841697	500206	65	50	16	8	K	920-0003 964-0003 1111-0003 17992-0003	09-1028B-9					
MKREC21213660	500207	57	31,5	16	12	K	1210-0003 3085-0003	09-1027B-9					
MKREC3593659	500216	51	22	12,7	6	I	673-0003	09-1026B-9					
MKREC6303-0001	500238	51	22	8	6	H	6303-0003	09-824P-9					
MKREC11979-0001	500155	65	36,5	16	8	K	11979-0001						
MKREC18789-0001	500144	117,6	88,9	25	9	K	17240-0001 18789-0001						
MKREC31500-0001		128	101,5	36	12	K	31500-0001						

IMPELLER & FUEL TANK SENSOR



YAMAHA

REF	CEF	A (mm)	B (mm)	C	BLADE	KEY TYPE	HP	YAMAHA
MKREC6G1-44352-00	500302	40	18	11,9	6	J	6, 8HP	6G1-44352-00
MKREC6H3-44352-00	500316	51,8	19,05	18,05	6	J	40, 50, 55, 70HP	6H3-44352-00 697-44352-00
MKREC682-44352-01	500320	40	22	13	6	J	9,9, 15HP	682-44352-01
MKREC662-44352-01	500321	40	22	14	6	J	6, 8 HP	662-44352-01
MKREC6L5-44352-00	500322	36	14,5	9,9	6	J	F2.5A , 3A Malta	6L5-44352-00
MKREC688-44352-03	500323	58	30	20,1	6	J	75, 85, 90 HP	688-44352-03
MKREC646-44352-01	500324	47,5	13,7	11,15	6	J	2HP	646-44352-01
MKREC6E0-44352-00	500325	40	12,6	11	6	J	4HP	6E0-44352-003
MKREC689-44352-02	500326	69,5	12,8	16,15	6	J	25-30 HP	689-44352-03
MKREC6F5-44352-00	500352	69,8	22,1	16,04	6	J	40 HP	6F5-44352-01 676-44352-00
MKREC63V-44352-01	500363	53	14	12,85	6	J	8, 9,9, 15 HP	63V-44352-01
MKREC67F-44352-00	500364	58,2	34,7	20	6	J	80-100 HP	67F-44352-01
MKREC68T-44352-00	500368	52,8	14	11,7	6	J	F6A, 6B, F8C	68T-44352-00
MKREC6E5-44352-01	500371	89	31	22,45	6	J	115, 150, 225, 250 HP	6E5-44352-03
MKREC6L2-44352-00	500384	51	19	14,1	6	J	20D, 25N	6L2-44352-00
MKREC6H4-44352-02	500385	51	19	16,1	6	J	25, 30, 40, 5HP	6H4-44352-01 676-44352-01

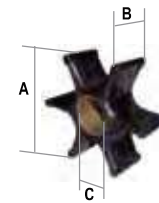

MKREC6H4-44352-02



MKREC6G1-44352-00



MKREC6H3-44352-00



MKREC682-44352-01



MKREC662-44352-01



MKREC6L5-44352-00



MKREC688-44352-03



MKREC646-44352-01



MKREC6E0-44352-00



MKREC689-44352-02



MKREC6F5-44352-00



MKREC63V-44352-01



MKREC67F-44352-00



MKREC68T-44352-00



MKREC6E5-44352-01



MKREC6L2-44352-00

SENDERS

LEVEL SENSOR FOR FRESH WATER OR FUEL

In stainless steel. Five holes fixing.

USA		EUROPA, VDO	
240 - 33 Ω		empty-full, 0-190 Ω	
REF	(mm)	REF	(mm)
MKRECJS60334	150 mm	MKRECJS60055	150 mm
MKRECJS60336	200 mm	MKRECJS60057	200 mm
MKRECJS60338	250 mm	MKRECJS60059	250 mm
MKRECJS60340	300 mm	MKRECJS60061	300 mm
MKRECJS60342	400 mm	MKRECJS60063	400 mm
MKRECJS60344	500 mm	MKRECJS60065	500 mm
MKRECJS60346	600 mm	MKRECJS60067	600 mm
MKRECJS60348	700 mm	MKRECJS60069	700 mm
MKRECJS60350	800 mm	MKRECJS60071	800 mm

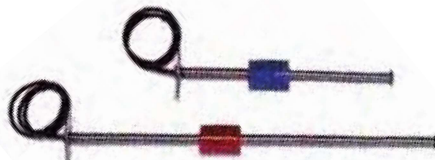

FUEL LEVEL SENDER

Five holes fixing.

REF	(mm)	
FA91001	8" - 16"	USA
FA91003	14" - 24"	USA
FA91005	20 - 40 cm	EURO
FA91007	36 - 60 cm	EURO

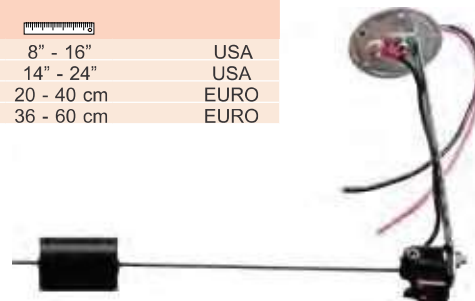

RUDDER ANGLE SENDER

For single station.

REF	
FA90530	For one station
FA90531	For dual station



INSTRUMENTATION

COMBINATION GAUGE

REF	⚡	∅
MKRECKY79202	■	51 mm
MKRECKY79303	□	12/24V 51 mm



VOLTMETER

REF	⚡	∅
MKRECKY13200	■	51 mm
MKRECKY13304	□	8-16V 51 mm



WATER TEMPERATURE

REF	🌡️	∅
MKRECKY14200	■	51 mm
MKRECKY14304	□	40-120°C 51 mm



OIL TEMPERATURE

REF	🌡️	∅
MKRECKY14202	■	51 mm
MKRECKY14305	□	50-150°C 51 mm



AMMETER

REF	⚡	∅
MKRECKY06200	■	51 mm
MKRECKY06300	□	±80A 51 mm



RUDDER ANGLE

REF	∅
MKRECKY09209	■
MKRECKY09309	□



RUDDER ANGLE SENDER

REF
MKRECKE41000



HOURMETER WHITE

REF	∅
MKRECKY39201	■
MKRECKY39200	□



VOLTMETER

Chesapeake SS White	Coral Black	⚡	Ø (mm)
FA13805	Fa13010	12V	51



Coral

Chesapeake

DECK CONNECTORS

WATERPROOF DECK CONNECTORS IN CHROMED BRASS

Waterproof deck connectors. Manufactured in chromed brass and plastic cap, with rubber seal.

Ref	⚡	PINS	🔌
MKGS11020	3 amp	2	1
MKGS11021	3 amp	3	1
MKGS11022	3 amp	4	1
MKGS11023	5 amp	2	1
MKGS11024	5 amp	3	1
MKGS11025	5 amp	4	1



BATTERY SWITCHES

MAIN BATTERY SWITCHES HEAVY DUTY

Battery selector switch made of reinforced polycarbonated housing. Tin-platted copper stud terminals. Case design allows panel or surface mounting. With ADF (Alternator Field Disconnect).

Ref	CONTINUOUS	INTERMITENT	MAX 0,25Sx 10	⚡	(mm)	🔌
BS3003	500A	700 A	1750 A	48V	98 x 98	1

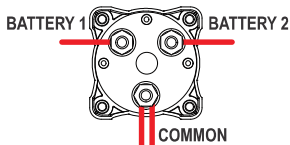

EUROPEAN FUEL LEVEL

Chesapeake SS White	Coral Black	⚡	Ø (mm)
FA13020	FA13818 "FUEL"	12V	51
FA13820	"WATER"		



Coral

Chesapeake

WATERPROOF DECK CONNECTORS IN NYLON

Waterproof deck connectors. Manufactured in reinforced nylon.

Ref	⚡	PINS	🔌
MKGS11030	3 amp	2	1
MKGS11031	3 amp	3	1
MKGS11032	3 amp	4	1



Battery selector switch made of reinforced polycarbonated housing. Tin-platted copper stud terminals. Case design allows panel or surface mounting. With ADF (Alternator Field Disconnect).

Ref	CONTINUOUS	INTERMITENT	MAX 0,25Sx 10	⚡	(mm)	🔌
BS3001	600A	900 A	2000 A	48V	98 x 98	1

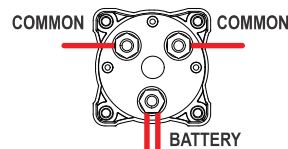

DUAL CIRCUIT PLUS

Switches two battery banks simultaneously while maintaining battery bank isolation, minimizing the risk of a dead Start battery. The COMBINE BATTERIES function offers the ability to combine two battery banks in the event of a low battery.

Ref	CONTINUOUS	INTERMITTENT	MAX. 0,25s x 10	(mm)	TERMINALS
BS6011	300A	450 A	1200 A	32V 72 x 72	3/8" - 16 1

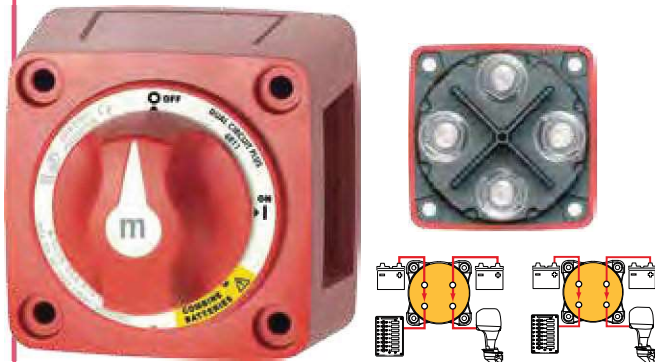

DUAL CIRCUIT

Switches both positive and negative lines simultaneously meeting European and metal boat requirements for a double pole switch. Switches circuits of different voltages, such as 12V and 24V.

Ref	CONTINUOUS	INTERMITTENT	MAX. 0,25s x 10	(mm)	TERMINALS
BS6010	300A	450 A	1200 A	32V 72 x 72	3/8" - 16 1



SELECTOR

Ref	CIRCUITS	CONTINUOUS	INTERMITTENT	MAX. 0,25Sx 10	(mm)
BS9002E	1 (ON/OFF) AFD	350 A	525 A	1500 A	36V DC 98 x 98 1



Battery selector switch made of polycarbonate and non-corrosive marine grade metals.

Ref	CONTINUOUS	INTERMITTENT	(mm)
MKGS11212	250A	350 A	Ø133



Single pole battery switch manufactured in black plastic finish with brass electrical contacts.

Ref	CONTINUOUS	INTERMITTENT
MKGS11200	100 A	500 A
MKGS11209	75 A	300 A



Single pole battery switch made of polycarbonate and non-corrosive marine grade metals.

Ref	CONTINUOUS	INTERMITENT	(mm)	
MKGS11211	250A	350 A	67 x 67	1
MKGS11210	250A	350 A	67 x 67	1



MKGS11211
Removable handle

MKGS11210

Single pole battery switch manufactured in brass and high impact plastic. Copper contacts. Removable handle.

Ref	CONTINUOUS	INTERMITENT	(mm)	(mm)	
MKGS11205	250 A	2500 A (5 s)	12/24 V	100 134 x 134 x 77	1



Single pole battery switch. Copper contacts. Removable handle.

Ref	CONTINUOUS	INTERMITENT	(mm)	
MKGS11206	Brass	150 A	1000 A (5 s) 12/24 V	58 1
MKGS11207	Stainless Steel	150 A	1000 A (5 s) 12/24 V	58 1



Single pole battery switch. Copper contacts. Removable handle.

Ref	CONTINUOUS	INTERMITENT	(mm)	
MKGS11208	75 A	300 A (5 s)	Ø 58	1



PANEL SWITCH

SWITCH PANEL

Aluminum plate with 3 illuminated rocker switches, battery test switch, cigarette lighter and fuse holders.

REF	(mm)	SWITCHES		
MKGS11189	165 x 115	3	15A 12V	1



Black bakelite plate, toggle switches and fuse holders

REF	(mm)	SWITCHES		
MKGS11190	115 x 90	3	15A 12V	1
MKGS11191	115 x 165	6	15A 12V	1



Silver anodized aluminum plate, illuminated rocker switches and fuse holders.

REF	(mm)	SWITCHES		
MKGS11192	115 x 90	3	15A 12V	1
MKGS11193	115 x 167	6	15A 12V	1



BILGE PUMP SWITCH PANELS

Contura switches with «ON» indicating LED embedded in switch.

REF	(mm)	ON - OFF - AUTO	1
MKGS20142	90 x 50	ON - OFF - AUTO	1



WATERPROOF SWITCH PANEL

In black plastic. Illuminated rocker switches and fuse holders.

REF	(mm)	SWITCHES	⚡	1
MKGS11176	110 x 130	3		1
MKGS11177	110 x 190	6		1



Waterproof switch panel in black anodized aluminum plate, switches with waterproof caps and circuit breakers.

REF	(mm)	SWITCHES	⚡	1
MKGS11170	90 x 100	3	12V (2x10A + 1x15A)	1
		ON-OFF-ON		
		ON-OFF MOM ON - OFF		
MKGS11171	170 x 100	6	12V (1x5A + 3x10A + 2x15A)	1
		ON-OFF-ON		
		ON-OFF MOM ON - OFF		

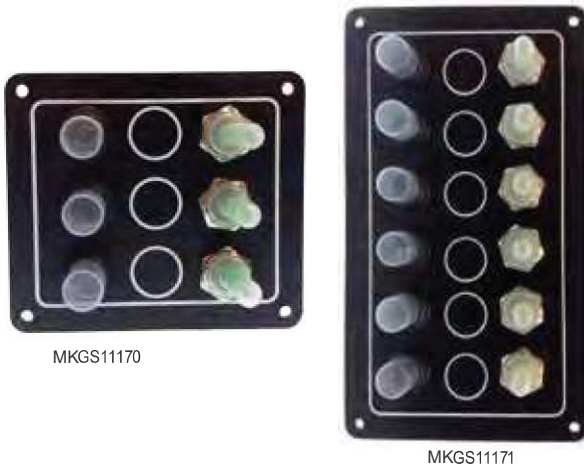

CUT OFF SWITCH

REF	OEM	OUTBOARD	1
MKREC37830-89E03	37830-84E03	Suzuki	1
MKREC37820-92E03	37820-92E00	Suzuki	1
MKREC69W-82575-00e	69W-82575-0	Yamaha / Mariner	1
MKREC688-82575-01	688-82575-01	Yamaha / Mariner	1
MKREC200		Mercury / Mariner	1
MKREC369-0682-0	369-0682-00	Tohatsu	



IGNITION STARTER SWITCHES

IGNITION STARTER SWITCHES

3 positions, Off-Run- Start. Magneto.

REF	OEM	PANELS	TERMINALS	POSITIONS	1
MKMP39200		28 mm	3	3	1



BULBS



KEY AND BULB

3 positions, Off-Run-Start. Conventional

REF	OEM	PANELS	TERMINALS	POSITIONS	
MKMP39760	393301 508180	28mm	5 + 1	3	1



3 positions, Off-Run-Start. Magneto

REF	OEM	TERMINALS	POSITIONS	
MKMP41070	MC 87-17009A2, 87-17009A5	6	3	1



3 positions, Off-Run- Start. Conventional.

REF	PANELS	TERMINALS	POSITIONS	
MKMP41030	15 mm	3	3	1



BULB BA9S

REF		Wat	CONTACTS	SOCKET		
					(mm)	
AM529337	12 V	20 W	1	BA9S	30 x 8,9	1
AM520053	12 V	1,7 W	1	BA9S	24,6 x 12,3	2
AM520057	12 V	3,4 W	1	BA9S	27,2 x 14,9	2
AM521895	12 V	3,8 W	1	BA9S	27,2 x 14,9	2
AM521816	12 V	4,3 W	1	BA9S	31,7 x 10,1	2
AM521416	12 V	10,2 W	1	BA9S	35 x 15	2



AM529337 AM520053 AM520057 AM521816 AM521416
AM521895

REF		Wat	CONTACTS	SOCKET		
					(mm)	
MKGS10139	12 V	5 W	1	BA9S	x 15	2



BULB FESTOON

REF		Wat	CONTACTS		
				(mm)	
AM522124	12 V	4,75 W	FESTOON	20,8 x 6,4	2
AM529102	12 V	10 W	FESTOON	31 x 10,9	2
AM529200	12 V	10 W	FESTOON	31 x 10,9	1
AM522129	24 V	10 W	FESTOON	31 x 10,9	1
AM529095	12 V	6 W	FESTOON	36 x 9,9	2
AM529104	12 V	8 W	FESTOON	31 x 10,9	2
AM522127	12 V	8 W	FESTOON	31 x 10,9	2
AM522112	12 V	15 W	FESTOON	43,9 x 10,9	2
AM522122	12 V	10 W	FESTOON	43,9 x 10,9	2



REF		Wat	CONTACTS		
				(mm)	
AM529333	12 V	8 W	FESTOON	43,9 x 10,9	2



REF		Wat	CONTACTS		
				(mm)	
MKGS10144	12 V	10 W	FESTOON	44 x 14 (8,5)	2
MKGS10132	24 V	10 W	FESTOON	40 x 11 (8,5)	2
MKGS10145	12 V	10 W	FESTOON	40 x 11 (8,5)	2
MKGS10146	12 V	5 W	FESTOON	44 x 11 (8,5)	2
MKGS10147	12 V	3 W	FESTOON	30 x 8 (7,25)	2



LED BULBS

G4 LED 15 SMD 5050

REF	WHITE	WARM	COOL	⚡ (V)	Wat	(mm)	
MKGS10512	✓			10-30	3	Ø 45	1
MKGS10513			✓	10-30	3	Ø 45	1

REF	WHITE	WARM	COOL	⚡ (V)	Wat	(mm)	
MKGS10514		✓		10-30	3	Ø 45	1
MKGS10515	✓			10-30	3	Ø 45	1
MKGS10516			✓	10-30	3	Ø 45	1

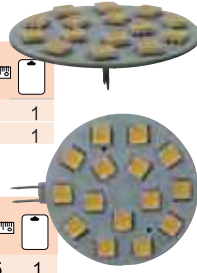

G4 LED 9 SMD 5050

REF	WHITE	WARM	COOL	⚡ (V)	Wat	(mm)	
MKGS10520		✓		10-30	1,8	Ø 30	1
MKGS10521	✓			10-30	1,8	Ø 30	1
MKGS10522			✓	10-30	1,8	Ø 30	1

REF	WHITE	WARM	COOL	⚡ (V)	Wat	(mm)	
MKGS10523	✓			10-30	1,8	Ø 30	1

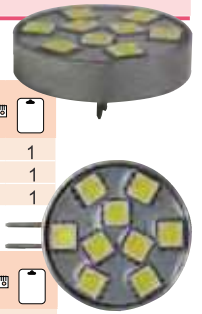

SEVERAL

SEALED BEAM

For spreader lights, spotlights, etc.

REF	⚡	WAT	(mm)	OPTICS
MKGS10185	12 V	35	Ø 114	Flood
MKGS10197	12 V	30	Ø 114	
MKGS10199	12 V	100	Ø 177	Spot
MKGS10186	28 V	50	Ø 114	



Manufactured in plastic and stainless steel with acrylic lens.

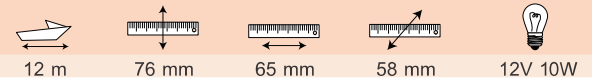

REF	REF	
MKGS10011	MKGS10041	112.5° 1
MKGS10012	MKGS10042	112.5° 1
MKGS10013	MKGS10043	225° 1
MKGS10014	MKGS10044	135° 1
MKGS10015	MKGS10047	225° 1

NAVIGATION LIGHTS

NAVIGATION LIGHTS

Manufactured in plastic and stainless steel with acrylic lens.

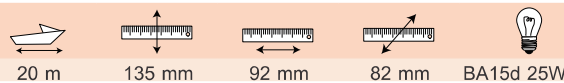

REF	
MKGS10001	112.5° 1
MKGS10002	112.5° 1
MKGS10003	225° 1
MKGS10004	135° 1
MKGS10005	225° 1



MKGS10005



MKGS10001

MKGS10002



MKGS10003

MKGS10004



DECK LIGHTS

Manufactured in anodized aluminum. Adjustable bracket.

REF			
		(mm)	
MKGS10241	IP68 5160 lumens 6 LED CREE x 10W	9-48V 60W 279 x 64 x 92	1
MKGS10373	IP68 10080 lumens 48 LED CREE x 3W	9-32V 144W 305 x 73 x 107	1
MKGS10374	IP68 13000 lumens 60 LED CREE x 3W	9-32V 180W 368 x 73 x 107	1



GS10241



GS10373





GS10374

CABIN LIGHTS

COURTESY LIGHT

Waterproof light. Aluminum base and lacquered brass cover.

REF			
		(mm)	
MKGS10227	G4 12V 10W	150 x 98 x 38	1







BATTERY CHARGER

BATTERY CHARGERS

AUTOMATIC BATTERY CHARGER

Automatic battery chargers. Automatic 6 steps charging curves. Easily choose 4 options: Flooded, Freedom, Gel, AGM Batteries by dip switch setting. 2 or 3 battery outputs. High ambient temperature rated. Automatic temperature compensation Complete protection. Reverse polarity protection. Anodized aluminum coated against salt moisture corrosion.

REF		BATTERIES	CAPACITY BATTERY			
					(mm)	KG
TBBP1212-2A	12V	2	12A	-20°C +70°C	300 x 190 x 70	2,0 kg
TBBP1225-3A	12V	3	25A	-20°C +70°C	300 x 190 x 70	2,5 kg
TBBP1240-3A	12V	3	40A	-20°C +70°C	350 x 190 x 70	2,8 kg
TBBP2412-3A	24V	3	12A	-20°C +70°C	300 x 190 x 70	2,5 kg
TBBP2420-3A	24V	3	20a	-20°C +70°C	350 x 190 x 70	2,8 kg



BATTERY ISOLATORS

Automatic battery isolators, allow 2 or more batteries to recharge at the same time using one or two generators (see technical specifications). The 'Very Low Drop' automatic battery isolators separate electrically each battery to prevent the battery with the highest charge from draining into the one with the lower charge. When charging, the battery isolator allows the preferential recharging of the battery bank most in need.

REF	ALTERNATOR	BATTERIES	MAX AMP
SICHPR10002	1	2	50A
SICHPR20002	1	3	50A
SICHPR30002	2	4	50A
SICHPR50002	2	2	100A
SICHPR70002	2	2	150A
SICHPR60002	2	3	100A



WIPERS

WIPER ARM

REF	FOR SHAFTS	UNION	(mm)	
MKGS12062	13 mm	7 mm	270 - 365	1



REF	FOR SHAFTS	UNION	(mm)	
MKGS12060	6 mm	5 mm	355	1



WIPER BLADE

All Stainless steel.

REF	UNION	(mm)	
MKGS12072	7 mm	280	1
MKGS12073	7 mm	355	1
MKGS12074	7 mm	406	1
MKGS12070	5 mm	280	1
MKGS12071	5 mm	355	1



Made in stainless steel. Curved blade.

REF	UNION	(mm)	
MKGS12084	7 mm	280	1
MKGS12085	7 mm	356	1
MKGS12086	7 mm	406	1
MKGS12087	7 mm	457	1
MKGS12088	7 mm	508	1



Made in polymer, glass impregnated with marine grade rubber squeegee.

REF	UNION	(mm)	
MKGS12095	7 mm	305	1
MKGS12097	7 mm	406	1
MKGS12099	7 mm	508	1



WIPER MOTOR

Stainless steel motor housing. 110° sweep. Self parking.

REF		SHAFT	
MKGS12052	12V	6 mm	Ø9 x 30 mm



Adjustable sweep angle: 83-100-110-120° 2 speeds. Self parking.

REF		SHAFT	
MKGS12058	12V	13 mm	Ø16 x 25 mm
MKGS12055	12V	13 mm	Ø16 x 50 mm
MKGS12066	24V	13 mm	Ø16 x 25 mm
MKGS12067	24V	13 mm	Ø16 x 50 mm



HORNS

ELECTRIC HORN

Stainless steel cover.

REF		
MKGS12001	12V	1
MKGS12002	12V	1



GS12001



GS12002

ANCHOR

FISHING NET HOOK

Manufactured in stainless steel AISI-316

Ref	KG	cm
MKGS61048	460 g	200 mm
MKGS61049	960 g	240 mm



FOLDING ANCHOR

Manufactured in galvanized steel.

Ref	KG
MKGS61010	1,5 kg
MKGS61011	2,5 kg
MKGS61012	3,2 kg
MKGS61013	4 kg
MKGS61014	6 kg
MKGS61015	8 kg
MKGS61027	10 kg
MKGS61028	12 kg
MKGS61029	15 kg



FOLDING ANCHOR S.S.

Manufactured in stainless steel AISI-316

Ref	KG
MKGS61016	1,5 kg
MKGS61017	2,5 kg
MKGS61018	4 kg



FENDER F



Ref		cm	KG
SCAFA520S	F-01S	13 x 37	0,62 kg
SCAFA520M	F-01M	13 x 46	0,68 kg
SCAFA520	F-01L	13 x 56	0,75 kg
SCAFA623	F-1	15 x 61	1 kg
SCAFA822	F-02	20 x 66	1,65 kg
SCAFA2	F-2	22 x 61	1,75 kg
SCAFA927	F-3	22 x 74	2,10 kg
SCAFA4	F-4	22 x 104	2,90 kg
SCAFA5	F-5	29 x 77	3 kg
SCAFA6	F-6	29 x 109	4,20 kg
SCAFA7	F-7	37 x 102	5,30 kg
SCAFA8	F-8	37 x 144	7,60 kg
SCAFA11	F-11	59 x 146	10,50 kg
SCAFA13	F-13	75 x 188	23 kg



FENDERS

BUOY-FENDER A



Ref	Ref	BUOYANCY	cm	KG
		GROSS	MAX.	
SCANB40B	A-1	13 kg	7,8 kg	33 x 38 cm 1,2 kg
SCANB50B	SCANB50R A-2	32 kg	19,2 kg	39 x 50 cm 2.1 kg
SCANB60B	SCANB60R A-3	52 kg	31,2 kg	46 x 57 cm 3.1 kg
SCANB75B	SCANB75R A-4	90 kg	64 kg	55 x 71 cm 4.1 kg
SCANB100B	SCANB100R A-5	215 kg	129 kg	71 x 94 cm 8.3 kg
SCANB110B	SCANB110R A-6	405 kg	243 kg	85 x 112 cm 11.3 kg
SCANB135B	SCANB135R A-7	670 kg	402 kg	110 x 142 cm 21.0 kg





FENDERS AND ANCHORS

TOWABLES

SPEEDZONE-1
SPEEDZONE-2
SPEEDZONE-3

SPORTSSTUFF

Heavy-gauge PVC and double-stitched nylon cover.
Reinforced tow system.



REF		
MKSPOR53-1920	1	Ø147 cm
MKSPOR53-1931	2	223 x 213 cm
MKSPOR53-1940	3	Ø 274 cm



AIR FORCE

SPORTSSTUFF

Heavy-gauge PVC and double-stitched nylon cover
Reinforced tow system..



REF		
MKSPOR53-1646	1	Ø 152 cm



HALF PIPE FRANTIC

SPORTSSTUFF

Heavy-gauge PVC and double-stitched nylon cover.
Reinforced tow system.



REF		
MKSPOR53-2160	1	203 x 284 cm



STUNT FLYER

SPORTSSTUFF

Heavy-gauge PVC and double-stitched nylon cover
Reinforced tow system..

REF		
MKSPOR53-1651	2	Ø 178 cm



ELECTRIC STANDARD TOILETS



ELECTRIC TOILET AND MANUAL TOILET

Electric standard space saver



Electric standard compact



Electric standard comfort



Laguna electric standard



Luxury low



Luxury standard



The well proven and popular electric standard toilets with combined pump unit for flushing and wasting . All metal parts and screws are in stainless steel. The base is in impact resistant material. Can be installed either above or below the sea level. A special macerator pump allows the expulsion up to 3.50 m in height. Self priming up to 1,5 mt. vertically. Equipped with seat lid and control panel. Port connections: inlet. 19mm. 3/4" and outlet 25/38mm. 1" & 1 1/2".

Part No.	BOWL TYPE	VOLT	AMP	SEAT TYPE	SOFT CLOSE	CONVERSION KIT	DIMENSION IN MM (width,depth,height)Open=height with seat open	KG
MK6500000412	SPACE SAVER	12	17	6500000002	YES	5500000712	335X420X345(630)OPEN	11
MK6500000424	SPACE SAVER	24	8	6500000002	YES	5500000724	335X420X345(630)OPEN	11
MK6500000712	COMPACT	12	17	6500000001	NO	5500000712	335X420X390(675)OPEN	12
MK6500000724	COMPACT	24	8	6500000001	NO	5500000724	335X420X390(675)OPEN	12
MK6700000712	COMPACT	12	17	6500000002	YES	5500000712	335X420X390(675)OPEN	11
MK6700000724	COMPACT	24	8	6500000002	YES	5500000724	335X420X390(675)OPEN	11
MK6700000812	COMFORT	12	17	6500000004	YES	5500000712	365X460X385(730)OPEN	12
MK6700000824	COMFORT	24	8	6500000004	YES	5500000724	365X460X385(730)OPEN	12
MK6500200912	LAGUNA	12	24	6500000002	YES	5500019112	340X405X410(720)OPEN	18
MK6500200924	LAGUNA	24	12	6500000002	YES	5500019124	340X405X410(720)OPEN	18
MK6500002412	LUXURY LOW	12	30	6500000007	YES	5500003812	365X455X385(790)OPEN	20
MK6500002424	LUXURY LOW	24	15	6500000007	YES	5500003824	365X455X385(790)OPEN	20
MK6500002612	LUXURY STD	12	30	6500000007	YES	5500003812	365X455X455(860)OPEN	22
MK6500002624	LUXURY STD	24	16	6500000007	YES	5500003824	365X455X455(860)OPEN	22

MANUAL TOILET

MANUAL TOILET

White porcelain bowl , with plastic seat and cover.

REF	330 mm	473 mm	416 mm	9,5 kg	3/4"	1 1/2"
MKGS50001						



MANUAL PUMP

REF	
MKGS50008	1



SERVICE KIT

REF	
MKGS50022	1



ELECTRIC EVOLUTION TOILETS



Matromarine has realized a range of toilets where performance, reliability, noise level and design have really reached the highest standards. The running cycle is completely automatic and eliminates wastewater through a high-performance pump that allows drainage of waste up to 4 m. in height and at a distance of 40 m. New flush pump integrated in the whole kit with 360° orientable discharge port connection 1" and 1 1/2". Noise level is optimized against the standard electric toilets and reduced up to 30% lower while performance is increased of 50%. A special new duck valve on the discharge port connection prevents any return of black water.

Part No.	BOWL TYPE	VOLT	AMP	SEAT TYPE	SOFT CLOSE	CONVERSION KIT	DIMENSION IN MM (width,depth,height)Open=height with seat open	KG
MK6400000712	COMPACT	12	17	6500000002	YES	5600000112	335X420X390(670)OPEN	10
MK6400000724	COMPACT	24	8	6500000002	YES	5600000124	335X420X390(670)OPEN	10
MK6400000812	COMFORT	12	17	6500000004	YES	5600000112	365X460X385(730)OPEN	11
MK6400000824	COMFORT	24	8	6500000004	YES	5600000124	365X460X385(730)OPEN	11
MK6400000312	SPACE SAVER	12	19	6500000002	YES	5600000112	335X420XX325(670)	9

ELECTRIC TOILET SILENT:

Electric silent compact/
Space saver



Electric silent comfort.



Deluxe STD. silent



flush pump or
electrovalve needs
to be ordered apart

Laguna electric silent
soft close seat



Luxury STD "soft close"
seat



Luxury low "soft close"
seat



Alternatively A Rocker
switch with
Carling components can
be supplied



All silent toilets are supplied with IC. Intelligent control system panel 3 function control :Before use,After use, Short use and with a Trimmer to regulate flow rate from 1 to 5 liters

Part No.	BOWL TYPE	VOLT	AMP	SEAT TYPE	SOFT CLOSE	CONVERSION KIT	DIMENSION IN MM (width,depth,height)Open=height with seat open	KG	BIDET FITTINGS
MK6600200412	SPACE SAVER	12	17	6500000002	YES	5600000712	335X420X345(620)OPEN	9,5	NO
MK6600200712	COMPACT	12	17	6500000002	YES	5600000712	335X420X390(670)OPEN	10	NO
MK6600200724	COMPACT	24	8	6500000002	YES	5600000724	335X420X390(670)OPEN	10	NO
MK6600200812	COMFORT	12	17	6500000004	YES	5600000712	365X460X385(730)OPEN	11	NO
MK6600200824	COMFORT	24	8	6500000004	YES	5600000724	365X460X385(730)OPEN	11	NO
MK6600200912	LAGUNA	12	19	6500000002	YES	5500019712	340X405X410(720)OPEN	18	NO
MK6600200924	LAGUNA	24	10	6500000002	YES	5500019724	340X405X410(720)OPEN	18	NO
MK6500002042	LUXURY LOW	12	30	6500000007	YES	5500019812L	365X455X385(790)OPEN	20	NO
MK6500002044	LUXURY LOW	24	16	6500000007	YES	5500019824L	365X455X385(790)OPEN	20	NO
MK6500002242	LUXURY STD	12	30	6500000007	YES	5500019812	365X455X455(860)OPEN	21	NO
MK6500002244	LUXURY STD	24	16	6500000007	YES	5500019824	365X455X455(860)OPEN	21	NO
MK6500003212	DELUXE STANDARD	12	25	6500000008	NO	5500019812	365X455X455(840)OPEN	21	YES
MK6500003224	DELUXE STANDARD	24	13	6500000008	NO	5500019824	365X455X455(840)OPEN	21	YES

MANUAL TOILETS:



Our newest design allows the boat owner or service agent to easily replace the existing toilet without having to bore new holes. Can easily substitute Jabsco, RM and many other brands. Fixing holes are same of Jabsco manual Toilet. The toilet may be mounted both above and below the waterline; the fitted pump is a self priming one; the reversible left-handed pump mounting enables to install the toilet indifferently on both sides; waste discharge is possible both overboard and into a holding tank on board; Soft close plastic seat or wooden seat- Gross weight 10 kg

- Kit conversions are interchangeable Jabsco, TMC, RM69,JP,etc.
- Reversible pump mounting on left or right handed installation
- Full sized external seal housing allows quick clean seal replacement and instant access to pump cylinder.
- Angled pump and long stroke for more comfortable operation
- Innovative brake bushing prevents annoying leakage at the handle
- Spray nozzle elbow and soft close seat

Part No.	BOWL TYPE	VOLT	SEAT TYPE	PORT CONNECTIONS	CONVERSION KIT	DIMENSION IN MM (depth,width,height)
6800200700	SPACE SAVER	YES	6500000002	inlet. 19 mm outlet 38 mm	6100000700	400x450x295mm
6600200700	COMPACT	YES	6500000002	inlet. 19 mm outlet 38 mm	6100000700	400x450x340mm
6600000700	COMPACT	NO	6500000001	inlet. 19 mm outlet 38 mm	6100000700	400x450x340mm
6600200800	COMFORT	YES	6500000004	inlet. 19 mm outlet 38 mm	6100000700	460x470x335mm

ELECTRIC TOILET

ELECTRIC TOILET

White porcelain bowl, with plastic seat and cover. Switch box included.

REF	⚡	↕	↔	↗	KG	⏻	⏻
MKGS50010	12 V	352 mm	360 mm	445 mm	11 kg	3/4"	1"
MKGS50011	24 V	352 mm	360 mm	445 mm	11 kg	3/4"	1"



LUX

REF	⚡	↕	↔	↗	KG	⏻	⏻
MKGS50012	12 V	460 mm	383 mm	480 mm	21 kg	3/4"	1"
MKGS50013	24 V	460 mm	383 mm	480 mm	21 kg	3/4"	1"



ACCESSORIES

TANK VENT FILTER

Active carbon filter for black water vents, it removes bad odours. Made of aluminium and nylon. Fitted with rubber coated stainless steel straps for bulkhead mounting. With female hose adaptors 1/2".

REF	↕	📦
MKGS50037	250 x Ø 50 mm	1



WASTE LEVEL INDICATOR

Warning panel waste tank level with pre-wired sender. With 4 leds + full led indicators. Max.depth: 25 cm. CE certification.

REF	⚡	↕	📦
MKGS50038	12V	87 x 75 mm	1



ELECTRIC HORN



Marine twin horn

Material:S.S304

MKNo.	DIA(MM)	LENGTH(MM)	12/24V
MK39004-12	101	390/475	12V 1930G
MK39004-24	101	390/475	24V 1930G
MK39004-12L	101	390/475	12V 1580G
MK39004-24L	101	390/475	24V 1580G

DECK FILL PLATES

REF	TIPO	H (mm)	D (mm)	d (mm)	d1 (mm)	d3 (mm)	di (mm)
SFCW201	Water	70	85	50	40	38	34
SFCF201	Fuel	70	85	50	40	38	34



DECK FITTINGS

DECK PLATE

Manufactured in precision casted stainless steel AISI-316.

REF			
MKGS31110	38 mm	WASTE	1
MKGS31111	38 mm	GAS	1
MKGS31112	38 mm	DIESEL	1
MKGS31113	38 mm	WATER	1
MKGS31115	50 mm	DIESEL	1
MKGS31116	50 mm	FUEL	1
MKGS31117	50 mm	WATER	1



Made in chrome plated bronze. With splash-proof lock.

REF			
MKGS31105	38 mm	FUEL	1
MKGS31106	50 mm	FUEL	1



Made in chrome plated bronze.

REF			
MKGS31100	38 mm	FUEL	1
MKGS31101	38 mm	WATER	1
MKGS31102	50 mm	FUEL	1
MKGS31103	50 mm	WATER	1
MKGS31107	38 mm	WASTE	1



Manufactured reinforced plastic.

REF			
MKGS31120	38 mm	GAS	1
MKGS31121	38 mm	WATER	1
MKGS31122	50 mm	GAS	1
MKGS31124	50 mm	GAS	1



LOCKS

Stainless steel AISI-316.

REF	(mm)	
MKGS72361	115 x 50	1
MKGS72396	100 x 30	1
MKGS72397	92 x 30	1



CLEATS

SKEENE FAIRLEADS

Made of stainless steel AISI-316.

Ref	(mm)	
MKGS70070	114 x 19 x 30	2
MKGS70071	148 x 27 x 38	2



MOORING CLEAT

Made of stainless steel AISI-316.

Ref	BASE (mm)	A (mm)	B (mm)	C (mm)	
MKGS70066	160 x 60	160	55	71,8	1
MKGS70067	170 x 67	200	75	77,3	1

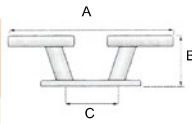

Ref	A (mm)	B (mm)	C (mm)	
MKGS70085	180	55	150	1
MKGS70086	240	90	200	1
MKGS70087	300	100	250	1
MKGS70088	350	115	300	1



FOLDAWAY CLEAT WITH SPRING LOCK

Made of stainless steel AISI-316.

Ref	BASE (mm)		
MKGS70065	195	150	1



CLEAT

Made of stainless steel AISI-316.

Ref		
MKGS70082	125	1
MKGS70060	153	1
MKGS70061	203	1
MKGS70062	250	1
MKGS70059	300	1
MKGS70083	153	1
MKGS70084	203	1



MKGS70082
MKGS70060
MKGS70061
MKGS70062
MKGS70059



MKGS70083

PUMP & PLUMBING



MK20701-1



MK20701-2



MK20701-3



MK20701-4

Hand Pump

MKNo.	HoseDia.	HandleMaterial
MK20701-1	34.5mm	Aluminium Alloy
MK20701-2	34.5mm	Plastic
MK20701-3	26mm	Stainless Steel
MK20701-4	38mm	Stainless Steel

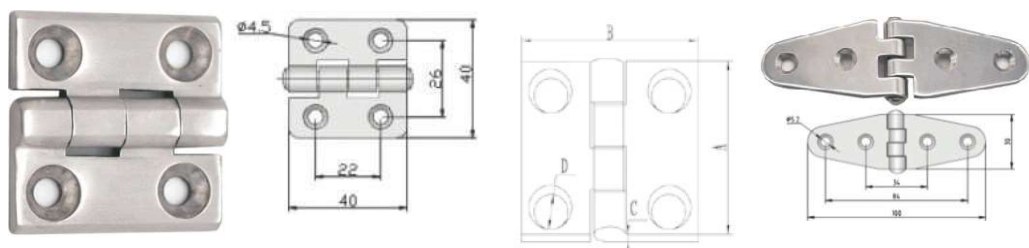

S.S.316 Hinge

No.	L	W	T
	mm	mm	mm
31004	100	30	2



S.S.316 Hinge

MKNo.	L	W	T
	mm	mm	mm
MK31001	40	40	2

S.S316 Hinge

MK.NO.	A	B	C	D
	(MM)	(MM)	(MM)	(MM)
MK31001s-1	38.1	38.1	4.5	5
MK31001s-2	50.5	50.5	4.5	5

S.S 316 Hinge

MKNO.	L	W	T
	MM	MM	MM
MK31004S	101.6	25.4	5

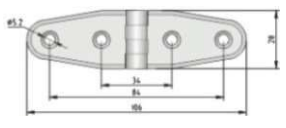
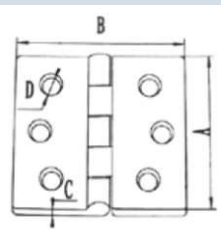

S.S.316 Hinge

MKNo.	L	W	T
	mm	mm	mm
MK31002-1	59	40	1.5
MK31002-2	80	60	1.5
MK31002-3	80	80	1.5

S.S316 Hinge

MK NO.	A	B	C	D
	(MM)	(MM)	(MM)	(MM)
MK31002s-1	63.5(2-1/2")	50.8(2")	2.5	5
MK31002s-2	63.5(2-1/2")	63.5(2-1/2")	3	5
MK31002s-3	76.2(3")	41.2(1-5/8")	3	5
MK31002s-4	76.2(3")	50.8(2")	3	5.5
MK31002s-5	76.2(3")	76.2 (3")	3	5.5

S.S.316 Hinge

MKNo.	L	W	T
	mm	mm	mm
MK31005	106	28	2

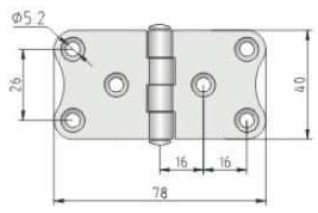

S.S.316 Hinge

MKNo.	L	W	T
	mm	mm	mm
MK31003	78	38	2
MK31003B	78	38	2

S.S316 Hinge

MKNO.	A	B	C	D	E
	(MM)	(MM)	(MM)	(MM)	(MM)
MK31003S-1	76.2	38.1	4.5	5.5	26.5
MK31003S-2	76.2	38.1	4.5	5.5	32

S.S.316 Hinge

MKNo.	L	W	T
	mm	mm	mm
MK31020	78	40	2

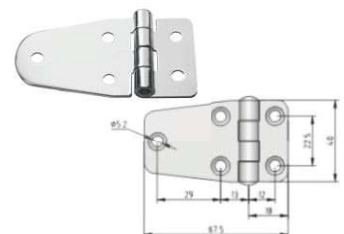
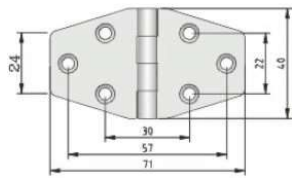
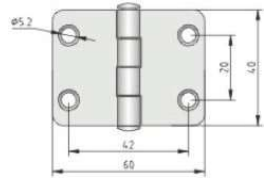
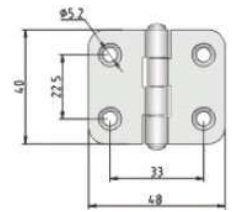

S.S.316 Hinge

MKNo.	L	W	T
	mm	mm	mm
MK31007	48	40	2

S.S.316 Hinge

MKNo.	L	W	T
	mm	mm	mm
MK31008	60	40	2

S.S.316 Hinge

MKNo.	L	W	T
	mm	mm	mm
MK31009	71	40	1.5

S.S.316 Hinge

MKNo.	L	W	T
	mm	mm	mm
MK31010	68	40	2

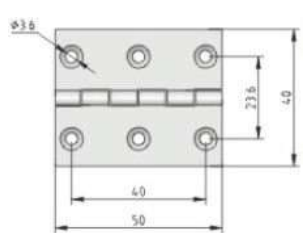
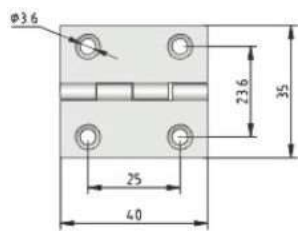
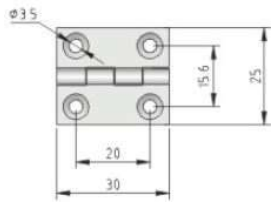

S.S.316 Hinge

MKNo.	L	W	T
	mm	mm	mm
MK31011-1	30	35	1
MK31011-2	40	35	1
MK31011-3	50	40	1



Types	I.D. mm.	O.D. mm.	L. mm.
500700K	22	29	75
500701K	22	36	80
500702K	25	36	100
500703K	25	40	120
500704K	30	40	120
500705K	35	54	140
500706K	40	54	140

Rubber bearings for french sailing boats
Boccole in gomma per barche a vela francesi

Reference	Shaft diameter		External diameter		Lenght	
	mm.	inch.	mm.	inch.	mm.	inch.
BAPM022038	22,22	7/8"	38,10	1"1/2	88,90	3"1/2
BAPM025031	25,40	1"	31,75	1"1/4	101,60	4"
BAPM025034	25,40	1"	34,92	1"3/8	101,60	4"
BAPM025050	25,40	1"	50,80	2"	101,60	4"
BAPM028038	28,57	1"1/8	38,10	1"1/2	114,30	4"1/2
BAPM028044	28,57	1"1/8	44,45	1"3/4	114,30	4"1/2
BAPM031038	31,75	1"1/4	38,10	1"1/2	127,00	5"
BAPM031041	31,75	1"1/4	41,27	1"5/8	127,00	5"
BAPM031050	31,75	1"1/4	50,80	2"	127,00	5"
BAPM034050	34,92	1"3/8	50,80	2"	139,70	5"1/2
BAPM034053	34,92	1"3/8	53,97	2"1/8	139,70	5"1/2
BAPM038060	38,10	1"1/2	60,32	2"3/8	152,40	6"
BAPM044066	44,45	1"3/4	66,67	2"5/8	177,80	7"
BAPM047074	47,62	1"7/8	74,61	2"15/16	190,50	7"1/2
BAPM050069	50,80	2"	69,85	2"3/4	203,20	8"
BAPM050076	50,80	2"	76,20	3"	203,20	8"
BAPM053069	53,97	2"1/8	69,85	2"3/4	215,90	8"1/2
BAPM053074	53,97	2"1/8	74,61	2"15/16	215,90	8"1/2
BAPM053079	53,97	2"1/8	79,37	3"1/8	215,90	8"1/2
BAPM057074	57,15	2"1/4	74,61	2"15/16	228,60	9"
BAPM057079	57,15	2"1/4	79,37	3"1/8	228,60	9"
BAPM057085	57,15	2"1/4	85,72	3"3/8	228,60	9"
BAPM060076	60,32	2"3/8	76,20	3"	241,30	9"1/2
BAPM060079	60,32	2"3/8	79,37	3"1/8	241,30	9"1/2
BAPM060085	60,32	2"3/8	85,72	3"3/8	241,30	9"1/2
BAPM063076	63,50	2"1/2	76,20	3"	254,00	10"
BAPM063079	63,50	2"1/2	79,37	3"1/8	254,00	10"
BAPM063085	63,50	2"1/2	85,72	3"3/8	254,00	10"
BAPM063088	63,50	2"1/2	88,90	3"1/2	254,00	10"
BAPM066088	66,67	2"5/8	88,90	3"1/2	266,70	10"1/2
BAPM069085	69,85	2"3/4	85,72	3"3/8	279,40	11"

Reference	Shaft diameter		External diameter		Lenght	
	mm.	inch.	mm.	inch.	mm.	inch.
BAPM069088	69,85	2"3/4	88,90	3"1/2	279,40	11"
BAPM073088	73,02	2"7/8	88,90	3"1/2	292,10	11"1/2
BAPM076095	76,20	3"	95,25	3"3/4	304,80	12"
BAPM076098	76,20	3"	98,42	3"7/8	304,80	12"
BAPM079114	79,37	3"1/8	114,30	4"1/2	317,50	12"1/2
BAPM082107	82,55	3"1/4	107,95	4"1/4	330,20	13"
BAPM085104	85,72	3"3/8	104,77	4"1/8	342,90	13"1/2
BAPM088107	88,90	3"1/2	107,95	4"1/4	355,60	14"
BAPM095127	95,25	3"3/4	127,00	5"	381,00	15"
BAPM095133	95,25	3"3/4	133,35	5"1/4	381,00	15"
BAPM101127	101,60	4"	127,00	5"	406,40	16"
BAPM107133	107,95	4"1/4	133,35	5"1/4	431,80	17"
BAPM111146	111,12	4"3/8	146,04	5"3/4	444,50	17"1/2
BAPM114142	114,30	4"1/2	142,87	5"5/8	457,20	18"
BAPM114146	114,30	4"1/2	146,05	5"3/4	457,20	18"
BAPM120152	120,65	4"3/4	152,40	6"	482,60	19"

Most of the size
may be ordered in different materials:
aluminium, pvc, POM-C.
Check availability.

*La maggior parte delle dimensioni
può essere ordinata anche in diversi materiali:
alluminio, pvc, POM-C.
Verificare la disponibilità.*

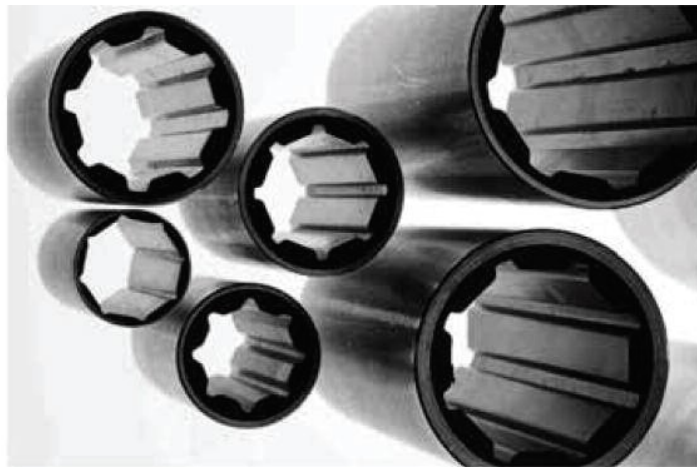

Reference	Shaft diameter		External diameter		Lenght	
	mm.	inch.	mm.	inch.	mm.	inch.
BAMS020030	20,00		30,00		80,00	
BAMS022035	22,00		35,00		88,00	
BAMS025035	25,00		35,00		100,00	
BAMS025040	25,00		40,00		100,00	
BAMS028038	28,00		38,00		112,00	
BAMS028042	28,00		42,00		112,00	
BAMS030040	30,00		40,00		120,00	
BAMS030045	30,00		45,00		120,00	
BAMS032045	32,00		45,00		128,00	
BAMS035048	35,00		48,00		140,00	
BAMS035050	35,00		50,00		140,00	
BAMS038055	38,00		55,00		152,00	
BAMS040055	40,00		55,00		160,00	
BAMS040056	40,00		56,00		160,00	
BAMS042060	42,00		60,00		168,00	
BAMS044068	44,00		68,00		180,00	
BAMS045061	45,00		61,00		180,00	
BAMS045065	45,00		65,00		180,00	
BAMS050066	50,00		66,00		200,00	
BAMS050070	50,00		70,00		200,00	
BAMS055073	55,00		73,00		220,00	
BAMS055075	55,00		75,00		220,00	

Reference	Shaft diameter		External diameter		Lenght	
	mm.	inch.	mm.	inch.	mm.	inch.
BAMS060078	60,00		78,00		240,00	
BAMS060080	60,00		80,00		240,00	
BAMS065083	65,00		83,00		260,00	
BAMS065085	65,00		85,00		260,00	
BAMS070090	70,00		90,00		280,00	
BAMS075095	75,00		95,00		300,00	
BAMS075096	75,00		96,00		300,00	
BAMS080100	80,00		100,00		320,00	
BAMS080102	80,00		102,00		320,00	
BAMS085105	85,00		105,00		340,00	
BAMS085110	85,00		110,00		340,00	
BAMS090110	90,00		110,00		360,00	
BAMS090115	90,00		115,00		360,00	
BAMS095115	95,00		115,00		380,00	
BAMS095123	95,00		123,00		380,00	
BAMS100125	100,00		125,00		400,00	
BAMS100130	100,00		130,00		400,00	
BAMS105130	105,00		130,00		420,00	
BAMS110135	110,00		135,00		440,00	
BAMS115140	115,00		140,00		460,00	
BAMS115145	115,00		145,00		460,00	
BAMS120140	120,00		140,00		480,00	

Other size available on request

Reference	Shaft diameter		External diameter		Lenght	
	mm.	inch.	mm.	inch.	mm.	inch.
BAMS120155	120,00		155,00		480,00	
BAPR020031	20,00		31,75	1"1/4	76,20	
BAPR022031	22,00		31,75	1"1/4	76,20	
BAPR025031	25,00		31,75	1"1/4	101,60	
BAPR025038	25,00		38,10	1"1/2	101,60	
BAPR028041	28,00		41,27	1"5/8	114,30	
BAPR030044	30,00		44,45	1"3/4	127,00	
BAPR032044	32,00		44,45	1"3/4	127,00	
BAPR035047	35,00		47,62	1"7/8	139,70	
BAPR038050	38,00		50,80	2"	152,00	
BAPR040053	40,00		53,97	2"1/8	160,00	
BAPR045060	45,00		60,32	2"3/8	177,80	
BAPR050066	50,00		66,67	2"5/8	203,20	
BAPR055076	55,00		76,20	3"	228,60	
BAPR060082	60,00		82,55	3"1/4	241,30	
BAPR065085	65,00		85,72	3"3/8	266,70	
BAPR070095	70,00		95,25	3"3/4	279,40	
BAPR075101	75,00		101,60	4"	304,80	
BAPR080101	80,00		101,60	4"	304,80	
BAPR085114	85,00		114,30	4"1/2	342,90	
BAPR090114	90,00		114,30	4"1/2	355,60	
BAPR095114	95,00		114,30	4"1/2	380,00	
BAPR100133	100,00		133,35	5"1/4	400,00	
BAPR105133	105,00		133,35	5"1/4	406,40	
BAPR110139	110,00		139,70	5"1/2	431,80	
BAPR115139	115,00		139,70	5"1/2	457,20	
BAPR120155	120,00		155,57	6"1/8	482,60	
BAPR125155	125,00		155,57	6"1/8	508,00	
BAPS025038	25,40	1	38,10	1"1/2	101,60	4"
BAPS028041	28,57	1"1/8	41,27	1"5/8	114,30	4"1/2
BAPS031044	31,75	1"1/4	44,45	1"3/4	127,00	5"

Reference	Shaft diameter		External diameter		Lenght	
	mm.	inch.	mm.	inch.	mm.	inch.
BAPS034047	34,92	1"3/8	47,62	1"7/8	139,70	5"1/2
BAPS038050	38,10	1"1/2	50,80	2"	152,40	6"
BAPS041053	41,27	1"5/8	53,97	2"1/8	165,10	6"1/2
BAPS044060	44,45	1"3/4	60,32	2"3/8	177,80	7"
BAPS047066	47,62	1"7/8	66,67	2"5/8	190,50	7"1/2
BAPS050066	50,80	2"	66,67	2"5/8	203,20	8"
BAPS053076	53,97	2"1/8	76,20	3"	215,90	8"1/2
BAPS057076	57,15	2"1/4	76,20	3"	228,60	9"
BAPS060082	60,32	2"3/8	82,55	3"1/4	241,30	9"1/2
BAPS063082	63,50	2"1/2	82,55	3"1/4	254,00	10"
BAPS066085	66,67	2"5/8	85,72	3"3/8	266,70	10"1/2
BAPS069095	69,85	2"3/4	95,25	3"3/4	279,40	11"
BAPS073095	73,02	2"7/8	95,25	3"3/4	304,80	12"
BAPS076101	76,20	3"	101,60	4"	304,80	12"
BAPS082101	82,55	3"1/4	101,60	4"	304,80	12"
BAPS085114	85,72	3"3/8	114,30	4"1/2	342,90	13"1/2
BAPS088114	88,90	3"1/2	114,30	4"1/2	355,60	14"
BAPS092114	92,07	3"5/8	114,30	4"1/2	368,30	14"1/2
BAPS095114	95,25	3"3/4	114,30	4"1/2	381,00	15"
BAPS098133	98,42	3"7/8	133,35	5"1/4	406,40	16"
BAPS101133	101,60	4"	133,35	5"1/4	406,40	16"
BAPS104133	104,77	4"1/8	133,35	5"1/4	419,10	16"1/2
BAPS107139	107,95	4"1/4	139,70	5"1/2	431,80	17"
BAPS111139	111,12	4"3/8	139,70	5"1/2	444,50	17"1/2
BAPS114139	114,30	4"1/2	139,70	5"1/2	444,50	17"1/2
BAPS117155	117,47	435/8	155,57	6"1/8	469,90	18"1/2
BAPS120155	120,65	433/4	155,57	6"1/8	482,60	19"
BAPS123155	123,82	4"7/8	155,57	6"1/8	495,30	19"1/2
BAPS127155	127,00	5"	155,57	6"1/8	508,00	20"
BAPM022031	22,22	7/8"	31,75	1"1/4	88,90	3"1/2
BAPM022034	22,22	7/8"	34,92	1"3/8	88,90	3"1/2

Other size available on request

PORTHOLES



OVAL SHAPE PORTHOLES

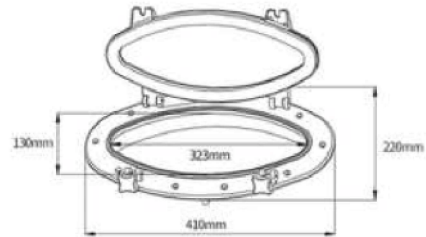

Code	Shape	Colour
MKPP1-03	Oval Shape Porthole	White
MKPP1-04	Oval Shape Porthole	Black

RECTANGULAR SHAPE PORTHOLES



Code	Shape	Colour
MKPP1-05	Rectangular Shape Porthole	White
MKPP2-06	Rectangular Shape Porthole	Black

PORTHOLES



PORTHOLES

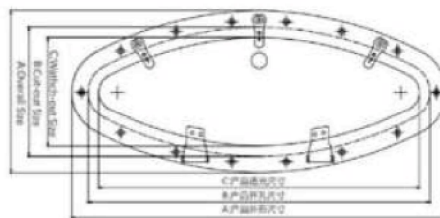

Standard Model (S) for FR/GRP/Wood		Super Thin Model for Aluminium/Steel Boat	
Item Code	Overall Size (mm)	Cut-Out Size (mm)	Suitable Hull Thickness (mm)
MK-Eye S-S	150X345	102X296	26-36
MK-Eye S-ST	150X345	102X296	6-16
MK-Eye-M-S	200X460	148X408	26-36
MK-Eye-M-ST	200X460	148X408	6-16
MK-Eye-B-S	250X575	203X526	26-36
MK-Eye-B-ST	250X575	203X526	6-16

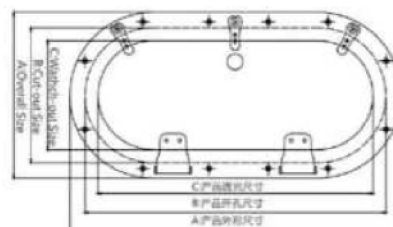

Standard Model (S) for FR/GRP/Wood		Super Thin Model for Aluminium/Steel Boat	
Item Code	Overall Size (mm)	Cut-Out Size (mm)	Suitable Hull Thickness (mm)
MK-Oval-S-S	150X345	101X297	26-36
MK-Oval-S-ST	150X345	101X297	6-16
MK-Oval-M-S	200X420	150X350	26-36
MK-Oval-M-ST	200X420	150X350	6-16
MK-Oval-B-S	250X560	202X511	26-36
MK-Oval-B-ST	250X560	202X511	6-16

PORTHOLES

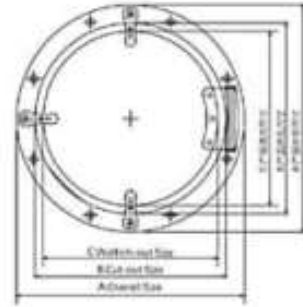

Standard Model (S) for FR/GRP/Wood		Super Thin Model for Aluminium/Steel Boat	
Item Code	Overall Size (mm)	Cut-Out Size (mm)	Suitable Hull Thickness (mm)
MK-Round-S-S	D200	D161	22-32
MK-Round-S-ST	D200	D161	6-16
MK-Round-M-S	D250	D205	28-38
MK-Round-M-ST	D250	D205	6-16
MK-Round-B-S	D300	D260	22-32
MK-Round-B-ST	D300	D260	6-16



Standard Model (S) for FR/GRP/Wood		Super Thin Model for Aluminium/Steel Boat	
Item Code	Overall Size (mm)	Cut-Out Size (mm)	Suitable Hull Thickness (mm)
MK-Rectangular-S-S	150X345	102X296	26-36
MK-Rectangular-S-ST	150X345	102X296	6-16
MK-Rectangular-M-S	200X460	152X411	26-36
MK-Rectangular-M-ST	200X460	152X411	6-16
MK-Rectangular-B-S	250X575	202X526	26-36
MK-Rectangular-B-ST	250X575	202X526	6-16

PORTHOLES

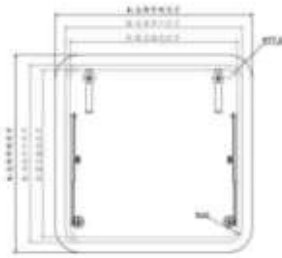

Standard Model (S) for FR/GRP/Wood		Super Thin Model for Aluminium/Steel Boat		
Item Code	Overall Size (mm)	Cut-Out Size (mm)	Suitable Hull Thickness (mm)	
MK375X375	375X375	310X310XR45	33-55	3-23
MK425X425	425X425	360X360XR45	33-55	3-23
MK475X475	475X475	410X410XR45	33-55	3-23
MK525X525	525X525	460X460XR45	33-55	3-23
MK575X575	575X575	510X510XR45	33-55	3-23
MK625X625	625X625	560X560XR45	33-55	3-23
MK625X625	625X625	610X610XR45	33-55	3-23



Standard Model (S) for FR/GRP/Wood		Super Thin Model for Aluminium/Steel Boat	
Item Code	Overall Size (mm)	Cut-Out Size (mm)	
MKD425	D425	D360	
MKD475	D475	D410	
MKD525	D525	D460	
MKD575	D575	D510	
MKD625	D625	D560	
MKD675	D675	D610	

PORTHOLES

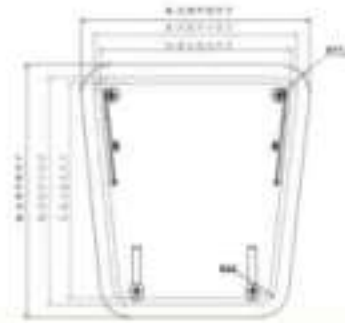

Standard Model (S) for FR/GRP/Wood		Super Thin Model for Aluminium/Steel Boat	
Item Code	Overall Size (mm)	Cut-Out Size (mm)	
MK-S	650X540	580X470	
MK-M	578X640	513X575	
MK-B	577X695	508X626	

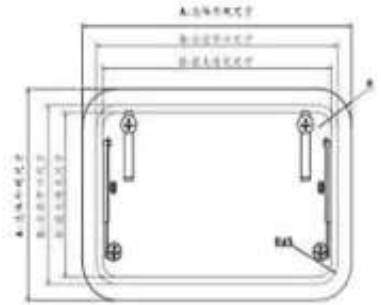

Standard Model (S) for FR/GRP/Wood		Super Thin Model for Aluminium/Steel Boat		
Item Code	Overall Size (mm)	Cut-Out Size (mm)	Suitable Hull Thickness (mm)	
MK425X525	425X525	360X460XR45	33-55	3-23
MK425X575	425X575	360X510XR45	33-55	3-23
MK425X625	425X625	360X560XR45	33-55	3-23
MK425X675	425X675	360X610XR45	33-55	3-23
MK475X575	475X575	410X510XR45	33-55	3-23
MK475X625	475X625	410X560XR45	33-55	3-23
MK475X675	475X675	410X610XR45	33-55	3-23
MK525X625	525X625	460X560XR45	33-55	3-23
MK525X675	525X675	460X610XR45	33-55	3-23
MK575X675	575X675	510X610XR45	33-55	3-23

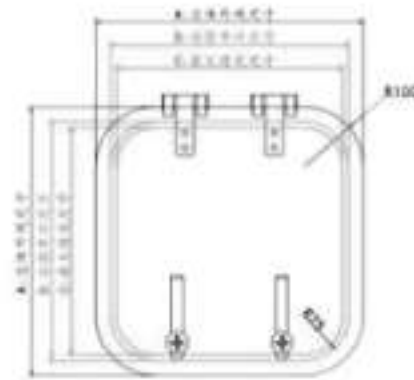

Standard Model (S) for FR/GRP/Wood		Super Thin Model for Aluminium/Steel Boat		
Item Code	Overall Size (mm)	Cut-Out Size (mm)	Suitable Hull Thickness (mm)	
MK-FH350X350	350X350	300X300XR75	23-50	3-23
MK-FH400X400	400X400	350X350XR75	28-50	3-23
MK-FH-450X450	450X450	400X400XR75	28-50	3-23
MK-FH500X500	500X500	450X450XR75	28-50	3-23
MK-FH550X550	550X550	500X500XR75	28-50	3-23



DECK HARDWARE LOCKS

MK 858PL



Front



Back

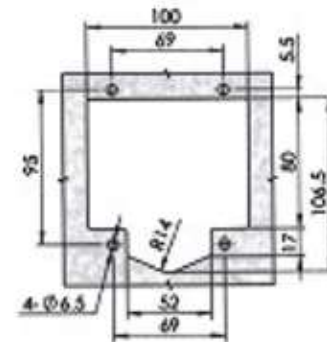
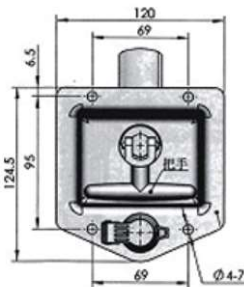
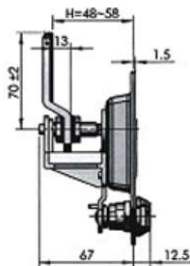
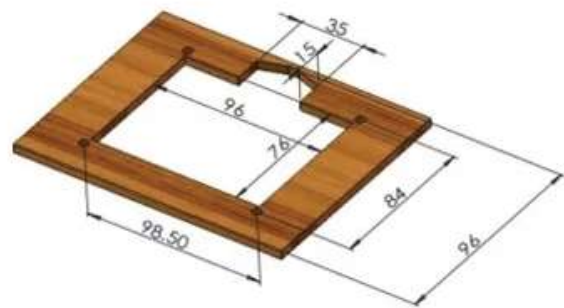
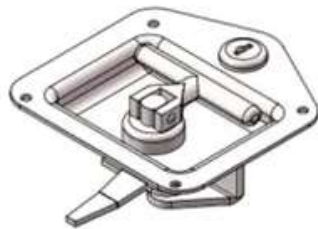

Item Number	MK858PL
Category	Panel Locks
Material	SS 304 Panel, Steel (Handle, Tongue & Parts)
Surface Finish	Mirror-Polished Chrome Plating, Zinc Coated
Weight	542g
Application	Deck Hardware, Panel Locks



MarineKart India



+91-992-302-6865
+91-9518-999-484



info@marinekartindia.com
sales@marinekartindia.com

Registered Office

No: F8, Vinayaki Building,
Opp. Fire Station Warkhandem
Ponda, Goa, India - 403 401

Showroom

Supreme by The Valley
Shop No: C-10, Near Mandovi
Clinic, Porvorim - Goa - 403 501

www.marinekartindia.com